

**DRG-T
RADIATION SURVEY
DEVICE**

**Operating Manual
BICT.412129.017-02 PӘ**

CONTENTS

1 DESCRIPTION AND OPERATION	5
1.1 Purpose of use	5
1.2 Key parameters and dimensions	5
1.3 Application parameters	6
1.4 Electronic counter-counter measures parameters	9
1.5 Factors of survivability and environmental stability	10
1.6 Factors of reliability, maintainability and storage	11
1.7 Delivery kit	12
1.8 Design and operation principle of the device	12
1.9 Labeling and sealing	19
1.10 Packing	20
2 PROPER USE	21
2.1 Operating limitations	21
2.2 Preparation for operation	21
2.3 Use of the device	24
3 TECHNICAL MAINTENANCE	25
3.1 Technical maintenance of the device	25
3.2 Verification of the device	26
3.3 Putting in prolonged storage	32
4 REPAIR	34
5 STORAGE	34
6 SHIPPING	35

This operating manual (hereinafter called the OM) is intended to inform the user about the principles of operation of the DRG-T radiation survey device, its operation procedure, and contains all information necessary for proper use of the device and full realization of its technical possibilities.

People, who were instructed on safety procedures and radiation safety and studied the operating manual, are admitted to operation with the device.

The OM contains the following abbreviations and symbols:

EDR	– exposure dose rate;
R/h	– roentgen per hour;
mR/h	– milliroentgen per hour;
POWER	– switch of the device power-on;
ON	– ON position of switch;
OFF	– OFF position of switch;
TEST	– switching elements group;
A	– commands test button „A”;
R	– commands test button „R”;
COMMANDS	– on/off switch of commands issuing to actuators;
+A	– gamma radiation scintillation detector center (A circuit)
+R	– gamma radiation detectors center (R circuit)
$K_{att.\gamma}$	– attenuation degree of gamma radiation of vehicle (an object of device installation)

1 DESCRIPTION AND OPERATION

1.1 Purpose of use

The DRG-T radiation survey device (hereinafter called the device) is designed to continuously measure exposure dose rate (EDR) of gamma radiation, and to provide audio and light alarm in case of a dangerous level of that radiation, and to issue commands to start the actuators of protection equipment.

The device is installed in special-purpose vehicles, in particular in radiochemical reconnaissance units of armed forces and civil defense, with the attenuation degree of gamma radiation ($K_{att,\gamma}$) from 1 to 35, and provides the possibility to set or change that degree in the device by the manufacturer as desired by the customer, or at departmental repair unit.

The device is produced in the following modifications:

Type	Modification	Language
BICT.412129.017	ДРГ-Т	Ukrainian
-01	ДРГ-Т	Russian
-02	DRG-T	English

1.2 Key parameters and dimensions

1.2.1 Measurement range of gamma radiation EDR – from $1 \cdot 10^{-5}$ to 1000 R/h.

1.2.2 Energy range of registered gamma radiation, from 0.66 to 1.25 MeV.

1.2.3 The device is powered from the DC onboard mains of 9.0 to 28.5 V voltage with electric power quality according to ГOCT B 21999-86.

1.2.4 Dimensions of the device - 160×160×66 mm (without a connector).

1.2.5 Weight of the device does not exceed 2 kg.

1.3 Application parameters

1.3.1 Main relative permissible error limit of gamma radiation EDR measurement $\delta\dot{X}$, in percentage, at calibration relative to ^{137}Cs with confidence probability of 0.95, is calculated by the formula:

$$\delta\dot{X} = 15 + \frac{0.2}{\dot{X}}, \quad (1.1)$$

where \dot{X} – is a numeric value of measured EDR in milliroentgens per hour.

1.3.2 Energy dependence of the device readings at measurement of gamma radiation is $\pm 25\%$ within the range of 0.66 to 1.25 MeV.

1.3.3 Anisotropy of the device is not more than $\pm 30\%$ for gamma radiation ^{137}Cs (at gamma quanta incidence at solid angle of $\pm 60^\circ$ relative to the main measurement direction, which is marked with the „+R” symbol).

1.3.4 Additional permissible error limit at measurement, caused by supply voltage variation from 9.0 to 28.5 V, does not exceed 10 %.

1.3.5 Additional permissible error limit at measurement, caused by ambient air temperature variation, does not exceed 5 % per each 10 °C deviation from 20 °C in the temperature range from – 40 °C to + 60 °C.

1.3.6 The device generates commands and signals (“R” circuit) with the parameters given in Table 1.1, in the presence of gamma radiation (for not less than 3 s) in the place of the device location with gamma quanta energy of 0.66 MeV, EDR of which in the device location exceeds the threshold level „R($K_{\text{att},\gamma}$)”, and in the mode of electrical test (when pushing the TEST R button). Commands and signals names and their parameters are given in Table 1.1.

Table 1.1 - Command and signals. “R” circuit

Signal (command) name	Signal (command) parameters	Actual data
Command „R”	Command presence: $U_{\text{com.R}} = U_{\text{onboard.m.}} \pm 2.0 \text{ V}$, $I_{\text{nom.com.R}} \leq 1.2 \text{ A}$	meets the requirements
	Command absence: $U_{\text{com.R}} \leq 0.7 \text{ V}$	
	Command duration: $t_{\text{com.R}} \geq 0.05 \text{ s}$	
Signal „R”	Signal presence: $U_{\text{sign.R}} = U_{\text{onboard.m.}} \pm 2.0 \text{ V}$, $I_{\text{nom.com.R}} \leq 0.1 \text{ A}$	meets the requirements
	Signal absence: $U_{\text{sign.R}} \leq 0.7 \text{ V}$	
	Signal duration: $t_{\text{sign.R}} \geq 10 \text{ s}$	
Light signal „R”	Periodic illumination of  symbol on the front panel of the device with $(0.8 \pm 0.3) \text{ s}$ interval.	meets the requirements
	Signal duration: $t_{\text{light.sign.R}} \geq 10 \text{ s}$	

1.3.6.1 The threshold level „R($K_{\text{att.}\gamma}$)” for the device to be installed in the vehicles with the attenuation degree of gamma radiation level $K_{\text{att.}\gamma} = 1$, is set in the range from $R_{\text{min}}(1) = 40 \text{ mR/h}$ to $R_{\text{max}}(1) = 60 \text{ mR/h}$.

For the devices to be installed in the vehicles with other values of attenuation degree of gamma radiation level $K_{\text{att.}\gamma}$, the threshold level „R($K_{\text{att.}\gamma}$)” is set within $R_{\text{min}}(K_{\text{att.}\gamma}) = R_{\text{min}}(1) / K_{\text{att.}\gamma}$ to $R_{\text{max}}(K_{\text{att.}\gamma}) = R_{\text{max}}(1) / K_{\text{att.}\gamma}$.

1.3.7 The device generates commands and signals (“A” circuit) with the parameters given in Table 1.2, in the presence of gamma radiation (for not less than 0.1 s) in the place of the device location with gamma quanta energy of 1.25 MeV, EDR of which in the device location exceeds the threshold level “A($K_{\text{att.}\gamma}$)”, and in the mode of electrical test (when pushing the TEST A button).

Table 1.2 - Command and signals. “A” circuit

Signal (command) name	Signal (command) parameters	Actual data
Command „A”	Command presence: $U_{com.A} = U_{onboard.m.} \pm 2.0 V$, $I_{nom.com.A} \leq 1.2 A$	meets the requirements
	Command absence: $U_{com.A} \leq 0.7 B$	
	Command duration: $t_{com.A} \geq 0.05 s$	
Signal „A”	Signal presence: $U_{sign.A} = U_{onboard.m.} \pm 2.0 V$, $I_{nom.com.A} \leq 0.1 A$	meets the requirements
	Signal absence: $U_{sign.A} \leq 0.7 V$	
	Signal duration: $t_{sign.A} \geq 10 s$	
Light signal „A”	Periodic illumination of  symbol on the front panel of the device with $(0.8 \pm 0.3) s$ interval.	meets the requirements
	Signal duration: $t_{light.sign.A} \geq 10 s$	

1.3.7.1 The threshold level „A($K_{att.\gamma}$)” for the device to be installed in the vehicles with the attenuation degree of gamma radiation level $K_{att.\gamma} = 1$, is set in the range from $A_{min}(1) = 11500 R/h$ to $A_{max}(1) = 17300 R/h$.

For the devices to be installed in the vehicles with other values of attenuation degree of gamma radiation level $K_{att.\gamma}$, the threshold level „A($K_{att.\gamma}$)” is set within $A_{min}(K_{att.\gamma}) = A_{min}(1) / K_{att.\gamma}$ to $A_{max}(K_{att.\gamma}) = A_{max}(1) / K_{att.\gamma}$.

1.3.8 In the presence of signals “R” or “A” the device generates audio signal “Aud. signal” and “Sign. RA” with the parameters presented in Table 1.3.

Table 1.3 – „Aud. signal” and „Sign. RA” parameters

Signal (command) name	Signal (command) parameter	Note
Audio signal „Aud. signal”	Signal presence: sequence of pulsed sendings of audio signal with a period $t_{\text{aud.}} = (1.25 \pm 0.4) \text{ ms}$, duration $T_{\text{send}} = (1.2 \pm 0.8) \text{ s}$, interval between sendings $T_{\text{int.aud.}} = (12 \pm 8) \text{ s}$ and pulse amplitude $U_{\text{aud.}} = 0.13 \dots 0.23 \text{ V}$ at load resistance $R_l = (600 \pm 60) \text{ Ohm}$	
Signal „Sign. RA”	Signal presence: duration of pulses $t_{\text{RA}} = 0.6 \dots 1.1 \text{ s}$ and period $T_{\text{RA}} = 1.2 \dots 2.2 \text{ s}$ with minimum voltage of $U_{\text{sign.RA1}}$ and maximum voltage $U_{\text{sign.RA2}}$, where $3 \text{ V} \leq U_{\text{sign.RA1}} \leq 8 \text{ V}$ $U_{\text{sign.RA2}} = U_{\text{onboard m.}} \pm 2,2 \text{ B}$ $I_{\text{nom}} \leq 0.1 \text{ A}$	
	Signal absence: $3 \text{ V} \leq U_{\text{sign.RA1}} \leq 8 \text{ V}$, $I_{\text{nom}} \leq 0.06 \text{ A}$	

1.3.9 Useful current of the device at operating supply voltage of 24 V does not exceed 1.0 A.

1.3.10 Time of continuous operation is not less than 48 hrs, and then it should be switched off at least for 2 hrs.

1.3.11 The device provides protection from short circuit at incoming and outgoing lines.

1.4 Electronic counter-counter measures parameters

1.4.1 The device does not create industrial low-frequency interference within 10 Hz to 10 kHz with voltage exceeding $(3.00 \pm 0.15) \text{ V}$ (maximum value) and $(300.00 \pm 0.15) \text{ mV}$ (root-mean-square value).

1.4.2 Electromagnetic compatibility of the device complies with the requirements of the paragraph 5 of ГOCT B 20.39.308-76.

1.5 Factors of survivability and environmental stability

1.5.1 The device is resistant to sinusoidal vibrations (when off) in the frequency range from 1 to 500 Hz with acceleration amplitude 59 m/s^2 (6 g).

1.5.2 The device is proof against sinusoidal vibrations (when on) in the frequency range from 1 to 500 Hz with acceleration amplitude 59 m/s^2 (6 g).

1.5.3 The device is resistant to mechanical shocks of single action with shock pulse duration from 0.2 to 2 ms, and shock acceleration peak value 4900 m/s^2 (500 g).

1.5.4 The device is resistant to mechanical shocks of repeated action with shock pulse duration from 5 to 15 ms, and shock acceleration peak value 196 m/s^2 (20 g).

1.5.5 When shipped in package the device is proof against shocks of repeated action with peak acceleration up to 196 m/s^2 (20 g), and shock pulse duration of 10 - 15 ms.

1.5.6 The device is proof against low temperature -40°C and resistant to maximum low temperature -50°C .

1.5.7 The device is proof against high temperature $+60^\circ\text{C}$ and resistant to maximum high temperature $+70^\circ\text{C}$.

1.5.8 The device is resistant to three temperature cycles in the temperature interval from maximum low temperature -50°C to maximum high temperature $+70^\circ\text{C}$.

1.5.9 The device is resistant to and proof against high humidity level of 98 % and $+25^\circ\text{C}$ temperature.

1.5.10 The device is resistant to and proof against working low atmospheric pressure of 60 kPa (450 mm Hg).

1.5.11 The device in shipping container is resistant to maximum low atmospheric pressure of 12 kPa (90 mm Hg).

1.5.12 The device is resistant to condensed atmospheric precipitations (hoarfrost, dew).

1.6 Factors of reliability, maintainability and storage

1.6.1 Mean time to failure – not less than 4000 hrs. Failure criterion is refusal of electrical test of the device performance, or no signals when “R” or “A” thresholds of gamma radiation EDR are exceeded.

1.6.2 Average operating life till the first major repair should be not less than 1600 hours, average service life till the first major repair – not less than 6 years.

1.6.3 Average service life of the device – not less than 20 years with maintenance check in 10 years.

1.6.4 Guaranteed shelf life – 6 months from the manufacture date.

1.6.5 Shelf life under conditions according to ГOCT B 9.003-80 (storage in heated premises and unheated storehouses in both manufacturer package, and as a part of the vehicle) – not less than 15 years.

1.6.6 Mean time of return to operation under conditions of departmental repair company or at producer-enterprise should be not more than 8 hours without considering the time for dismantling, shipping and verification after repair.

1.7 Delivery kit

The delivery kit of the device corresponds to Table 1.4

Table 1.4 – Delivery kit of the device

Type	Item	Quantity	Note
BICT.412129.017-02	DRG-T radiation survey device	1	
BICT.412129.017-02 PЭ	Operating manual	1	
BICT.412129.017-02 ФО	Logbook	1	
BICT.411915.013	Package	1	
Mounting parts kit (MPK)*			
ГЕ0.364.126 ТУ	Receptacle 2PMT22КПЭ10Г1В1В	1	
* MPK is used by the user during installation onsite			

1.8 Design and operation principle of the device

1.8.1 Design description.

The device (according to Figure 1) is a 150x160x66 mm rectangular parallelepiped, consisting of joined together housing 1 and cover 2.

In the top of the front surface of the device housing there is a black panel 3, where the following is highlighted:

- with green color – transparency of “R” signal (a zone);
- with yellow color – numeric value of gamma radiation EDR, failure signal (d zone), EDR unit of measurement mR/h (c zone);
- with red color – EDR unit of measurement – R/h (b zone) and transparency of “A” signal (e zone).

In the bottom of the front surface of the device housing there are the POWER switch 4 of the device power-on/-off, and under the TEST flap lid 7 there are the COMMANDS on/off switch 10 of “A” and “R” commands issuing to actuators, TEST – A, R buttons 11, 12.

On the top side surface of the housing there is the table 6 with an identification mark and a serial number of the device.

On the bottom side surface of the housing there are the X1 connector 9 and the ground bus 8, fixed to the X2 clamp (Б6 -300 OCT4.209.007 – 82).

For mounting the device in the vehicle its housing contains fixed rubber bumpers 5 with metal bushings at the four corners.

The rear surface of the device (cover 2) contains labeling „+R” (gamma detectors center of R circuit) and „+A” (gamma scintillation detector center of A circuit) that are used for calibration and verification of the device.

The device is sealed in the recesses of the cover, filled with bitumen mastic, with QCD and (or) CO seals.

The outer surfaces of the device are light grey. Captions and symbols (except for those indicated on the panel) are black.

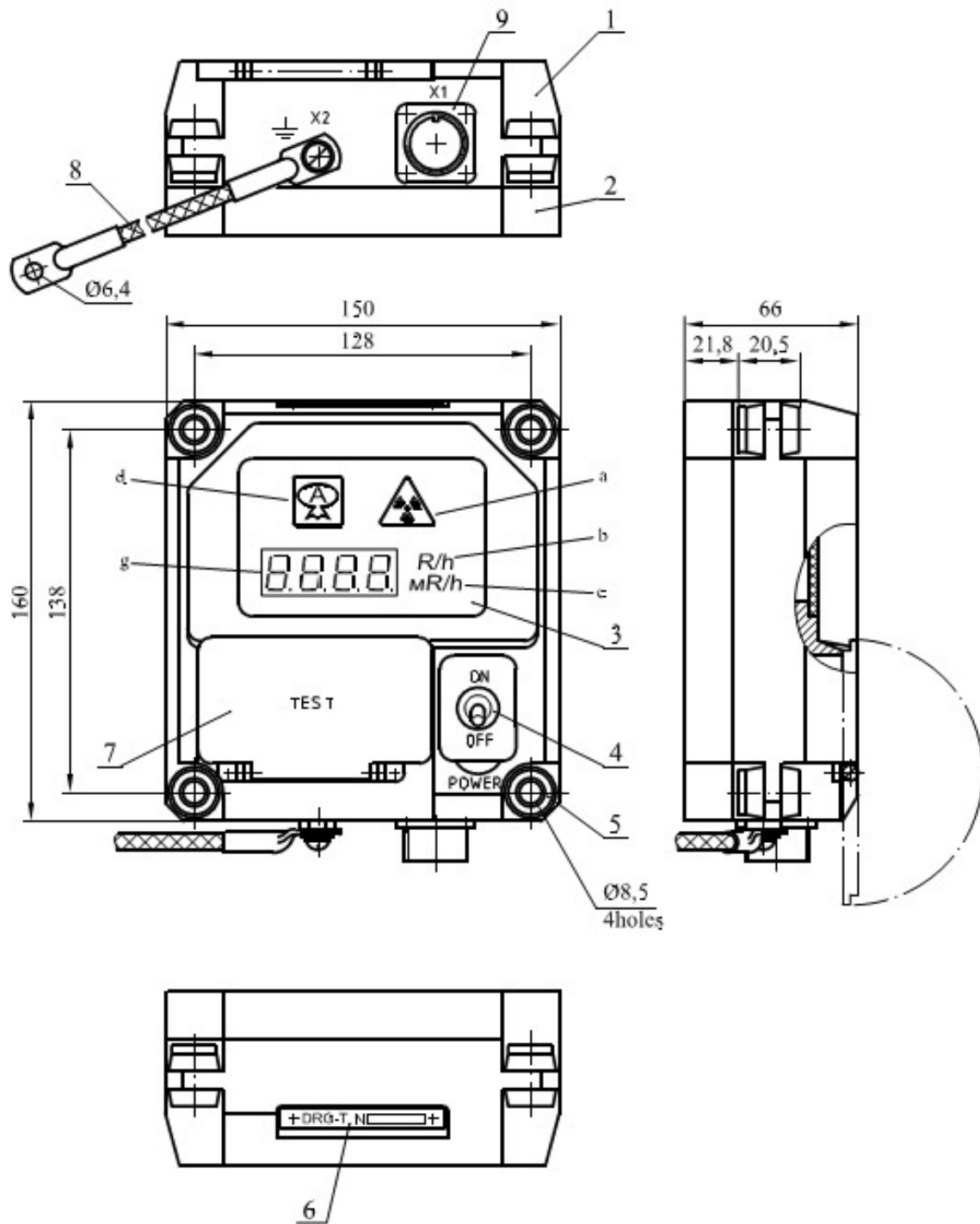

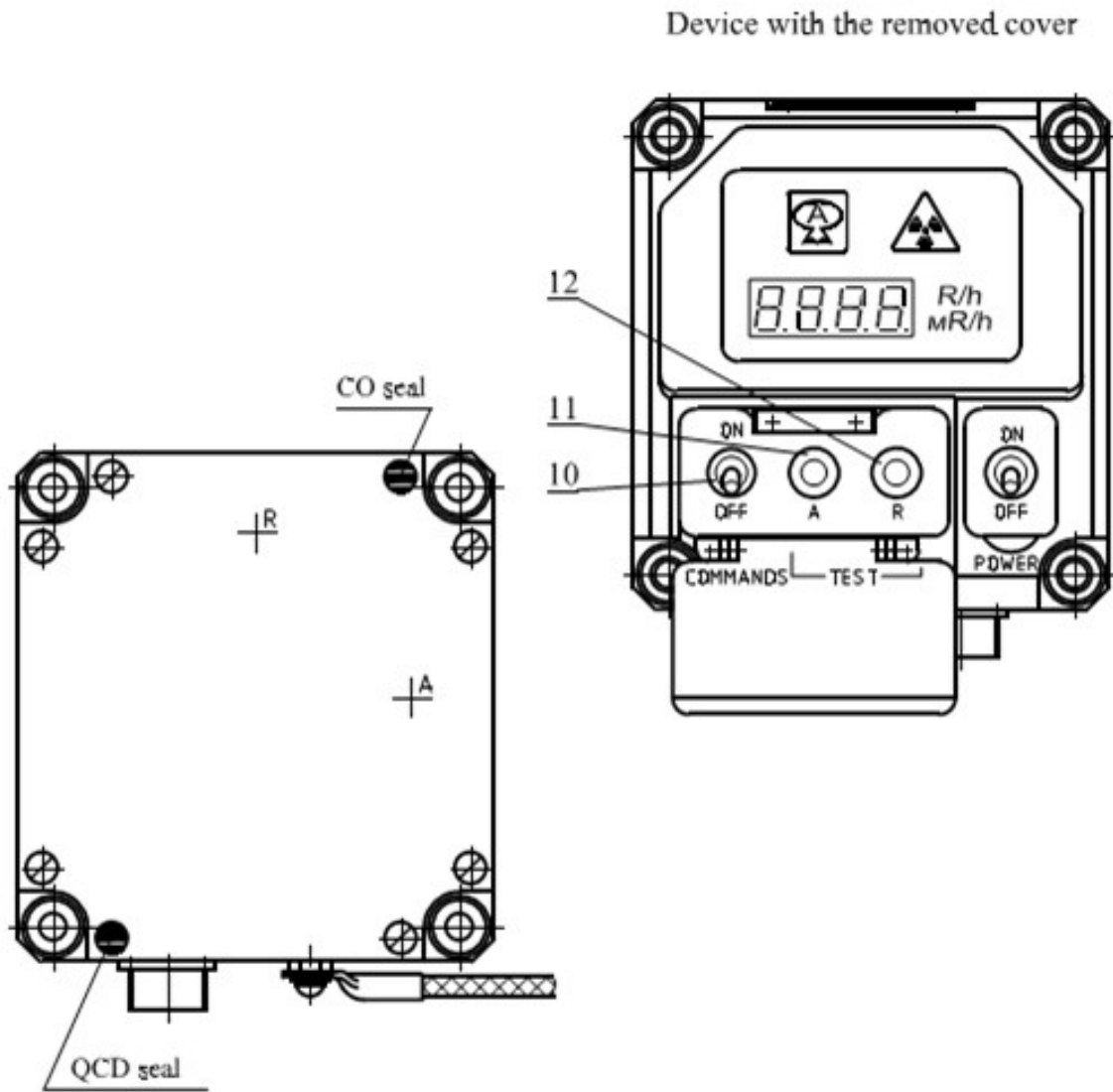

Figure 1 – Main appearances of DRG-T device

1.8.2 Operation of the device.

Operation of the device is illustrated with the help of the device structure chart, given in Figure 2.

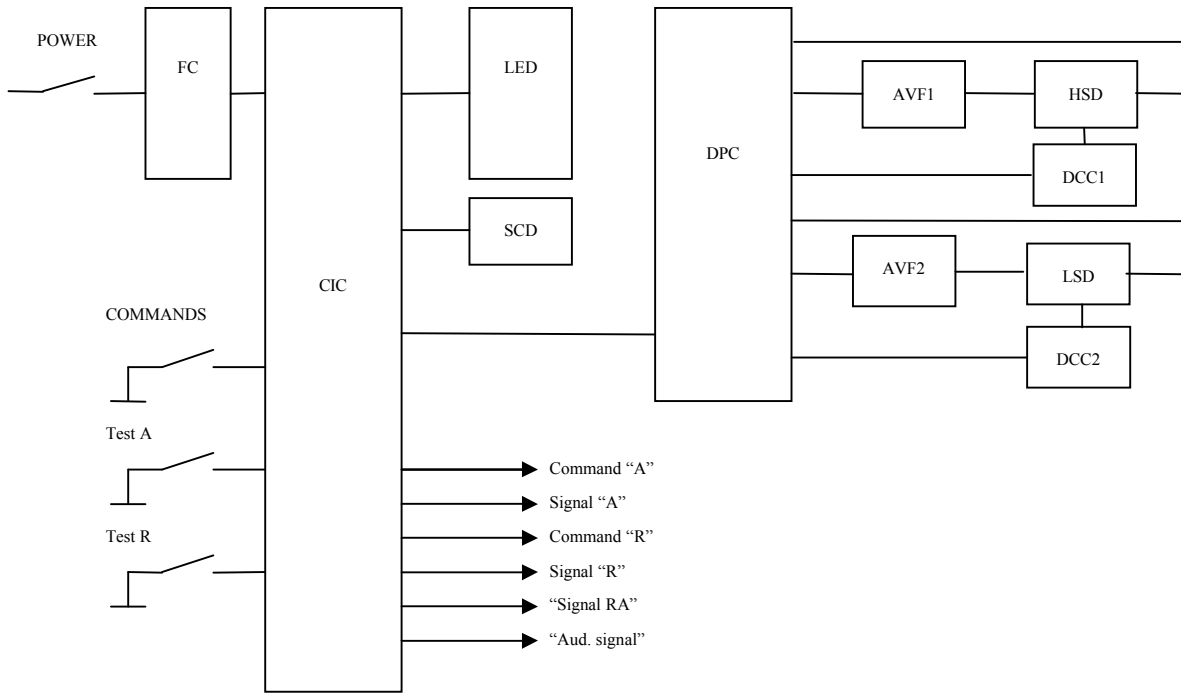

Figure 2 - Structure chart of the device

According to its structure chart the device consists of the feed circuit (FC), buttons TEST R and TEST A, switches POWER and COMMANDS, the control and indication circuit (CIC), the digital light-emitting diode (LED), the gamma radiation scintillation detector (SCD), the digital processing circuit (DPC), the anode voltage former for high-sensitivity detector (HSD) of gamma radiation (AVF1), the HSD control circuit (DCC1), the anode voltage former for low-sensitivity detector (LSD) of gamma radiation (AVF2), the LSD control circuit (DCC2).

The feed circuit (FC) serves to form voltages of the device circuit power supply.

Buttons TEST R and TEST A serve to launch the mode of electrical test of the device, the COMMANDS switch serves to turn on/off commands issuing to the actuators, the POWER switch powers on/off the device.

The control and indication circuit (CIC) and the digital processing circuit (DPC) are realized on the basis of microprocessors, and are used to control operating modes of the device, control the anode voltage former, digitally process pulse trains from the gamma radiation detector, generate signals that control the digital light-emitting diode indicator, as well as to display the measurement modes indicators and generate signals for the actuators.

The anode voltage formers (AVF1 and AVF2) are designed according to the circuit of the start-stop multivibrator with transformer voltage multiplication, and serve to form the anode voltage that is necessary to ensure operation of gamma detectors.

The control circuits of gamma radiation detectors (DCC1, DCC2) are designed based on a number of switching and normalizing elements, and serve to rate the detectors “dead time”.

A Geiger-Muller tube counter of CBM-20-1 type is used as the high-sensitivity detector of gamma radiation (HSD). It detects gamma radiation, the parameters of which are measured by the device.

A Geiger-Muller tube counter of СИ-3БГ type is used as the low-sensitivity detector of gamma radiation (LSD). It detects gamma radiation, the parameters of which are measured by the device.

In order to detect a high-level gamma radiation EDR (atomic explosion) a scintillation detector (SCD) is used, designed on the basis of a scintillation crystal CsJ and a solid-state photodiode. There is an optical contact between the photodiode and the scintillator. The operation principle of the detector lies in generation of photo current by the photodiode as a result of scintillations in the CsJ crystal during exposure to radiation. The output current of the detector is proportional to the intensity and energy of gamma radiation getting into the detector.

The digital light-emitting diode indicator (LED) is used for visualization of measurement results. It consists of four single-digit digital LED indicators and LED matrixes that are used to highlight the units of measurement being measured, and to provide light indication of radiation danger signals „A” and „R”.

The device works in the following way.

After supply voltage is supplied, the DPC with the help of the AVF2 starts forming 400 V anode voltage for the LSD. As a result of the LSD irradiation a pulse flux is formed at the outlet with a frequency that is proportional to gamma radiation EDR, registered by the LSD. With the help of the DCC2, the DPC rates the “dead time” of the LSD, makes up for the number of lost pulses and measures average pulse flux rate. The DPC transforms the measured rate value into the numeric value of gamma radiation EDR. Depending on the EDR, an integration time is automatically chosen that is enough to provide the statistical error of measurement lower than the main relative permissible error. The DPC concurrently measures an average pulse rate from the LSD for 1 s time interval, and on the basis of its value decides whether it is possible to continue work with the LSD, or necessary to switch to work with the HSD.

If there is a need to switch to operation with the HSD, the DPC stops generating the anode voltage for the LSD and processing the pulse flux from it, and starts operation with the HSD. Operation with the HSD is much the same as with the LSD. But a decision about the necessity to switch to operation with the LSD is made on the basis of the average pulse rate value from the HSD.

Simultaneously the CIC processor starts polling the DPC and controlling the signal from the SCD. Gamma radiation EDR values, received from the DPC, are controlled for exceeding the specified threshold, and displayed on the LED indicator. If the threshold is exceeded, the CIC generates light and audible alarm about a dangerous radiation level, and issues commands to start the actuators of protection equipment.

1.8.3 Requirements to the device location in the vehicle.

The distance from the device contour to the structural elements of the vehicle should be not less than 3 mm.

Location in the vehicle should provide the operator with a good visual observation of information on the panel, and a convenient access to the controls of the device.

1.9 Labeling and sealing

1.9.1 Labeling of the device complies with the requirements of GOST 26828-86 and drawings of the producer enterprise, and contains:

- identification mark of the device;
- serial order number of the device according to the numbering system of the producer enterprise.

1.9.2 Sealing is performed by the contracting officer (CO) and (or) QCD of the producer enterprise. After being accepted by the QCD and CO and prepared to sealing and packing, the device is sealed with the QCD and CO seal in the recesses, filled with bitumen mastic, in the places indicated in the DD (design documentation) of the producer enterprise.

Removal of seals and repeated sealing is performed by the company in charge of repair or verification.

1.9.3 Labeling of the shipping container complies with the requirements of GOST 14192-96; it is done according to the drawings of the producer enterprise, contains main, additional and informational letterings, as well as handling marks “This side up”, “Fragile – Handle with care”, and “Protect from humidity”.

1.10 Packing

The device is packed in a special packing box that ensures shipping by all means of transport and possibility of putting in prolonged storage (reconservation) according to ГOCT 9.014-78 using the B3-10 protection option.

The device is placed in a plastic sachet together with the receptacle 2PMT22KПЭ10Г1B1B GE0.364.126 TY, covered in parchment paper, and silicagel bags. The device is separated from bags with the help of the carton separator. The sachet is sealed, placed in the box and forced with the inside cover with the help of six screws.

The documentation is packed in a plastic sachet, which is welded after packing performed, and placed in the box. The outage is filled with cardboard. The box is closed with the cover and sealed with two seals according to ГOCT 18677-73.

2 PROPER USE

2.1 Operating limitations

Operating limitations are presented in Table 2.1.

Table 2.1 - Operating limitations

Operating limitation	Limitation parameters
1 Ambient air temperature	from -50 to $+70$ °C
2 Relative humidity	up to 98 % at 25 °C temperature

2.2 Preparation for operation

2.2.1. Safety measures.

The device contains no external parts exposed to voltages hazardous for life.

During operation with ionizing radiation sources, the radiation safety requirements stated in the following documents should be met:

“Radiation Safety Standards of Ukraine”, approved by the Minister of Health of Ukraine as of July 14, 1997;

“Main sanitary regulations of radiation protection of Ukraine” (2005), approved by the order of the Ministry of Health of Ukraine as of February 2, 2005.

Direct use of the device is not dangerous for the service personnel and is environmentally friendly.

A special protection jacket is used to prevent accidental contact with conductive parts. Ingress protection rating is IP56 according to ГOCT 14254-96.

The device is explosion- and fire-proof and complies with the requirements of ГOCT 12.1.004-91, ГOCT 12.2.007.0-75 fire safety standards.

2.2.2 Scope and order of external examination.

2.2.2.1 Before using the device, unpack it, remove from the prolonged storage, and check if the delivery kit is complete. Examine for mechanical damage.

Fix the device in its place in the vehicle and connect it to the onboard mains. The diagram of the device connection to the onboard mains of the vehicle is shown in Figure 3.

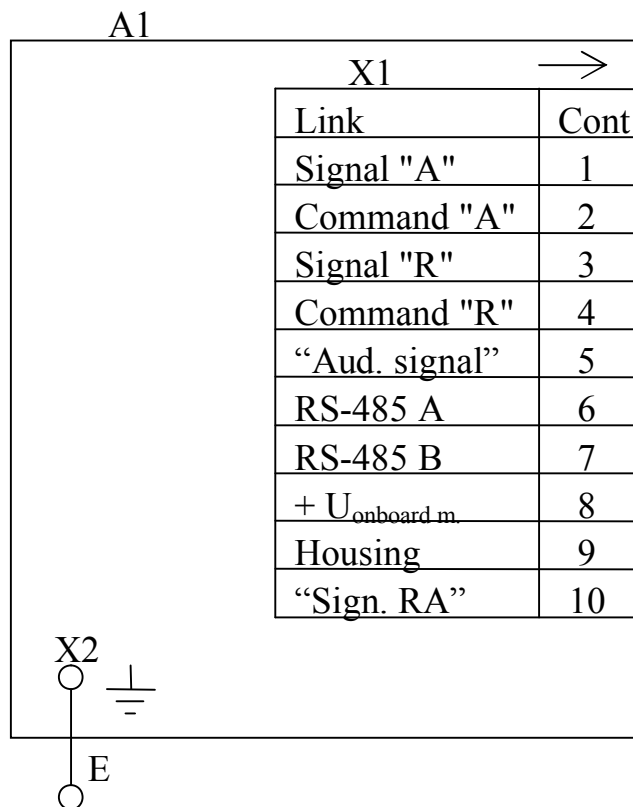

A1 – DRG-T device

E – bus Б6-300 ОСТ4 209007-82

X1 – plug 2РМГ22Б10Ш1В1 ГЕ0.364.140 ТУ



X2 – clamp СКЖД.57471.007-03 ОСТ4.2098.007-82

Ground bus E should be connected with the vehicle body.

Figure 3. Diagram of the device connection to the onboard mains of the vehicle

2.2.2.2 Make records in the logbook about removal from the prolonged storage and putting the device in operation.

2.2.3 Guidelines on switching on and testing the device with description of testing procedure of the device performance.

2.2.3.1 Switch on the device using the POWER switch. During 5 seconds check if all segments and dots of the digital indicator are lighted up and the transparencies of the units of measurement, the transparency of the “R” signal (symbol ) and the transparency of the “A” signal (symbol ) are highlighted.

Press the TEST R button. Check if the  symbol is highlighted on the front panel of the device.

Press the TEST A button. Check if the  symbol is highlighted on the front panel of the device.

2.2.3.2 Check commands and signals issuing by the device to the protection system of the vehicle according to the operating manual of the vehicle.

2.2.4 List of possible troubles and troubleshooting.

2.2.4.1 The list of possible troubles and troubleshooting is presented in Table 2.2.

Table 2.2 - List of possible troubles and troubleshooting

Trouble	Probable cause	Troubleshooting
1 The device is not switched on with the POWER switch	Break of the supply voltage conductor	Repair conductor break in the connecting cable
2 One or several signals or commands are not issued	Conductors break in the connecting cable	Repair conductors break in the connecting cable

2.2.4.2 At failure to eliminate the troubles presented in Table 2.2, or at detection of more complicated troubles, the device should be sent for repair to the repair services, or to the producer enterprise.

2.3 Use of the device

2.3.1 Operation procedure of the maintenance personnel during use of the device.

The device is switched on and off with the POWER switch.

The mode of gamma radiation EDR measurement is turned on as soon as the device is on. The first measurement results from the moment the device is on (or after a sharp change of radiation environment) are statistically invalid (measurement error can exceed the permissible one), but these results enable fast evaluation of gamma radiation EDR. Invalidity is shown with periodic illumination of the unit of measurement on the front panel of the device that continues till statistically reliable information is gained. Then it becomes continuously highlighted. The duration of statistical processing depends on the radiation intensity, and may last from 2 s to 2 min.

Measurement intervals from 2 s to 2 min and subranges are set automatically depending on the measured radiation intensity.

The operations procedure of the maintenance personnel under the conditions of dangerous level of gamma radiation EDR (when „A” or „R” commands and signals are issued) is determined by the operating manual of the vehicle, where the device is installed.

2.3.2 List of operating modes of the device.

The main operating mode of the device is the mode of gamma radiation EDR measurement. The additional mode is the mode of electrical test of the device.

2.3.3 Procedure and rules of switching the device between the operating modes.

To switch on the mode of electrical test of the device, use the TEST R and TEST A buttons. In 20 s after the mode has been switched on the device automatically returns to its main operating mode.

2.3.4 Safety measures during use of the device for the purpose specified.

The device contains no external parts exposed to voltages hazardous for life.

Direct use of the device is not dangerous for the service personnel and is environmentally friendly.

A special protection jacket is used to prevent accidental contact with conductive parts. Ingress protection rating is IP56 according to GOST 14254-96.

The device is explosion- and fire-proof and complies with the requirements of GOST 12.1.004-91, GOST 12.2.007.0-75 fire safety standards.

3 TECHNICAL MAINTENANCE

3.1 Technical maintenance of the device

3.1.1 General instructions.

Technical maintenance of the device is subdivided into check inspection (hereinafter called CI), technical maintenance No. 1 (hereinafter called TM-1) and technical maintenance No. 2 (TM-2).

3.1.2 Safety measures.

Safety measures during TM fully comply with safety measures presented in section 2.2.1 of the OM.

3.1.3 Maintenance procedure of the device.

3.1.3.1 CI is performed by the personnel who use the device before the beginning of operations, trainings, while preparing to march or shipping, and after the above stated actions.

CI includes: external examination (check for the absence of mechanical damage, integrity of protective glass and insulating coatings, connecting cable damage); cleaning of external surfaces from dust and impurities; check for the accuracy of switches fixation, condition of inscriptions; operability check according to the operating manual; elimination of the detected defects.

3.1.3.2 TM-1 is carried out on an annual basis, or when the device is placed on a short-term storage. TO-1 includes the actions stated in CI, as well as repair of lacquer coating if necessary, SPTA condition and completeness check, cleaning of contact surfaces and oiling of connector thread, check for correct keeping of maintenance documents, elimination of the detected defects.

3.1.3.3 TM-2 is carried out once every three years, and is combined with the periodic verification, or with putting or removal from the prolonged storage.

TM-2 includes all actions stated in TM-1, as well as periodic verification of the device, putting in prolonged storage (reconservation), maintenance documents condition check and records about performed operations. Verification is done by the military metrology laboratories, the other operations are performed by the personnel who use and store the device.

3.2 Verification of the device

Periodic verification of the devices that are in use should be performed at least once every 3 years (when used under constant or periodic influence of ionizing radiation the interval between verifications becomes 2 times smaller).

The device is verified according to the state metrological instruction МИ 1788-87 in compliance with the technique given below.

3.2.1 Verification operations.

During verification perform the operations presented in Table 3.1.

Table 3.1 - Verification operations

Operation name	Verification technique No.
1 External examination	3.2.4.1
2 Testing	3.2.4.2
3 Check of measurement range and main relative permissible error limit at gamma radiation EDR measurement	3.2.4.3
4. Check of „R” threshold level of commands and signals generation („R” circuit)	3.2.4.4
5. Check of „A” threshold level of commands and signals generation („A” circuit)	3.2.4.5

3.2.2 Verification facilities.

The following measuring instruments and equipment should be used during verification:

- УИГД-2 gamma-monitoring calibration equipment;
- special metrological equipment with highly active standard sources ^{60}Co .

- TEC 23 HTP 30.2.5 DC power supply, output voltage (24.0 ± 0.5) V, output current from 0 to 2.5 A.

Note – Use of other measuring equipment that meets the specified accuracy and has the specified features is allowed.

All verification facilities should obtain valid certificates of verification or state metrological certification.

3.2.3 Verification conditions.

Verification should be carried out in compliance with the following conditions:

- temperature, °C: (20 ± 5) ;
- relative air humidity, %: (60 ± 15) ;
- atmospheric pressure, kPa: (101.3 ± 4.0) ;
- natural background level of gamma radiation: not more than 0.025 mR/hour;
- power supply voltage: within (24.0 ± 0.5) V.

3.2.4 Verification procedure.

3.2.4.1 External examination.

During external examination the device should meet the following requirements:

- delivery kit should be completed as described in section 1.7;
- certificate about previous verification (metrological certification) should be available;
- labeling should be accurate;
- QCD and CO seals should not be violated;
- the device should be free from mechanical damage that may affect its performance.

Note – The delivery kit completeness is checked only at manufacture.

3.2.4.2 Testing.

Connect the device to power supply with $U_{\text{onboard m.}} = (24 \pm 1)$ V voltage (device connection diagram is shown in Figure 3).

Switch on the device. The digital indicator and measurement unit transparency (mR/h) should be highlighted on the front panel. The device should measure external radiation background level.

Push the TEST R button. Check if the  symbol is highlighted on the front panel of the device.

Push the TEST A button. Check if the  symbol is highlighted on the front panel of the device.

3.2.4.3 Check of gamma radiation EDR measurement range and main relative permissible error limit.

3.2.4.3.1 Switch on the device. Fix it in the УПГД-2 carriage holder, so that the mechanical center of gamma quanta beam coincides with the center of gamma detector, marked with a "+R" symbol. In 2 minutes after the measurement unit transparency on the front panel of the device has become constantly highlighted, perform five measurements of external background EDR and register the received readings in the protocol.

Calculate an average value $\overline{\dot{X}_{\phi}}$ of background gamma radiation EDR by the formula:

$$\overline{\dot{X}_{\phi}} = \frac{\sum_{i=1}^5 \dot{X}_i}{5} \quad (3.1)$$

Place the УПГД-2 carriage with the device in a position, where EDR from ^{137}Cs source is (0.08 ± 0.02) mR/h.

In 2 minutes after the measurement unit transparency on the front panel of the device has become constantly highlighted, perform five measurements of EDR sum from source and background $\dot{X}_{\gamma\phi i}$. Register the received readings in the protocol.

Calculate an average value of sum of gamma radiation EDR and background by the formula 3.2:

$$\bar{\dot{X}}_{\gamma\phi} = \frac{\sum_{i=1}^5 \dot{X}_{\gamma\phi i}}{5} \quad (3.2)$$

Calculate an actual measured value of gamma radiation EDR \dot{X}_{γ} by the formula:

$$\dot{X}_{\gamma} = \bar{\dot{X}}_{\gamma\phi} - \bar{\dot{X}}_{\phi}, \quad (3.3)$$

where $\bar{\dot{X}}_{\gamma\phi}$ - is an average value of the device readings from the source and external gamma background in mR/h;

$\bar{\dot{X}}_{\phi}$ - is an average value of the device readings of external gamma background measurement in mR/h.

3.2.4.3.2 The confidence limit of main relative permissible error of gamma radiation EDR measurement in percentage should be determined using the technique according to ГOCT 8.207-76 by the formula:

$$\Delta = 1.1 \sqrt{\delta\dot{X}_{\gamma}^2 + \delta\dot{X}_0^2}, \quad (3.4)$$

where $\delta\dot{X}_{\gamma}$ - is a relative error of measurement result, calculated by the formula:

$$\delta\dot{X}_{\gamma} = \frac{\dot{X}_{\gamma} - \dot{X}_0}{\dot{X}_0} \quad (3.5)$$

$\delta\dot{X}_0$ - is a main relative permissible error limit of gamma radiation EDR from sample gamma source.

3.2.4.3.3 Place the УПГД-2 carriage with the device in a position, where EDR from ^{137}Cs source is (0.8 ± 0.2) mR/h.

In 2 minutes after the measurement unit transparency on the front panel of the device has become constantly highlighted, perform five measurements of EDR.

Register the received readings in the protocol.

Calculate an actual measured EDR value by the formula (3.3) and a confidence limit of main relative error at measurement according to 3.2.4.3.2.

3.2.4.3.4 Place the УПГД-2 carriage with the device in a position, where EDR from ^{137}Cs source is (8 ± 2) mR/h.

After the measurement unit transparency on the front panel of the device has become constantly highlighted, perform five measurements of EDR.

Register the received readings in the protocol.

Calculate an actual measured EDR value by the formula (3.3) and a confidence limit of main relative error at measurement according to 3.2.4.3.2.

3.2.4.3.5 Place the УПГД-2 carriage with the device in a position, where EDR from ^{137}Cs source is (80 ± 20) mR/h.

After the measurement unit transparency on the front panel of the device has become constantly highlighted, perform five measurements of EDR.

Register the received readings in the protocol.

Calculate an actual measured EDR value by the formula (3.3) and a confidence limit of main relative error at measurement according to 3.2.4.3.2.

3.2.4.3.6 Place the УПГД-2 carriage with the device in a position, where EDR from ^{137}Cs source is (800 ± 200) mR/h.

After the measurement unit transparency on the front panel of the device has become constantly highlighted, perform five measurements of EDR.

Register the received readings in the protocol.

Calculate an actual measured EDR value by the formula (3.3) and a confidence limit of main relative error at measurement according to 3.2.4.3.2.

3.2.4.3.7 Place the УПГД-2 carriage with the device in a position, where EDR from ^{137}Cs source is (8 ± 2) R/h.

After the measurement unit transparency on the front panel of the device has become constantly highlighted, perform five measurements of EDR.

Register the received readings in the protocol.

Calculate an actual measured EDR value by the formula (3.3) and a confidence limit of main relative error at measurement according to 3.2.4.3.2.

3.2.4.3.8 Place the УПГД-2 carriage with the device in a position, where EDR from ^{137}Cs source is (80 ± 20) R/h.

After the measurement unit transparency on the front panel of the device has become constantly highlighted, perform five measurements of EDR.

Register the received readings in the protocol.

Calculate an actual measured EDR value by the formula (3.3) and a confidence limit of main relative error at measurement according to 3.2.4.3.2.

The testing result is acknowledged to be positive, if the main relative error of the device reading in a position where EDR equals (0.08 ± 0.02) mR/h, does not exceed 17.5 %, while in other positions it should not exceed 15 %.

3.2.4.4 Threshold levels check („R” circuit) (1.3.6.1).

Fix the device in the УПГД-2 carriage holder, so that the mechanical center of gamma quanta beam coincides with the center of gamma detector, marked with a "+R" symbol. Place the УПГД-2 carriage with the device in a position, where EDR from ^{137}Cs source is $R_{\min.}(K_{\text{att.}\gamma})$, and make sure that the light signal „R” is not generated.

Place the УПГД-2 carriage with the device in a position, where EDR from ^{137}Cs source is $R_{\max.}(K_{\text{att.}\gamma})$. Open the collimator for at least 3 s and make sure that the light signal „R” is generated in this position.

The testing result is acknowledged to be positive and the device meets the requirements of 1.3.6.1, if the light signal „R” is generated in the position, where gamma radiation EDR equals to $R_{\max.}(K_{\text{att.}\gamma})$, and is not generated in the position, where gamma radiation EDR equals to $R_{\min.}(K_{\text{att.}\gamma})$.

3.2.4.5 Threshold levels check („A” circuit) (1.3.7.1).

Fix the device in the carriage holder of the special metrological equipment, so that the mechanical center of gamma quanta beam coincides with the center of gamma detector marked with the "+A" symbol.

Place the carriage of the special metrological equipment with the device in a position, where EDR from ^{60}Co source is $A_{\min.}(K_{\text{att.}\gamma})$, and make sure that the light signal „A” is not generated.

Place the carriage of the special metrological equipment with the device in a position, where EDR from ^{60}Co source is $A_{\max.}(K_{\text{att.}\gamma})$.

Open the collimator for at least 0.1 s and make sure that the „A” signal is on. This means that the “A” threshold level complies with the requirements of 1.3.7.1.

The testing result is acknowledged to be positive and the device meets the requirements of 1.3.7.1, if the light signal „A” is generated in the position, where gamma radiation EDR equals to $A_{\max.}(K_{\text{att.}\gamma})$, and is not generated in the position, where gamma radiation EDR equals to $A_{\min.}(K_{\text{att.}\gamma})$.

3.2.4.6 Presentation of verification results.

3.2.4.6.1 Positive results of periodic verification are certified by the issued certificate of the established form by ДСТУ 2708:2006, or by the record in the section “Periodic testing of key specifications” of the logbook of the device.

3.2.4.6.2 The devices that do not meet the requirements of the verification technique are not allowed for use, and get the Certificate of Inadequacy according to ДСТУ 2708:2006.

3.3 Putting in prolonged storage

3.3.1 Putting in prolonged storage (reconservation) is done to protect the device from high air humidity levels during storage. Only a technically sound and a fully completed device can be put in prolonged storage.

Putting in prolonged storage (reconservation) is done directly in storehouses or special premises under the ambient air temperature not lower than +15 °C, and relative humidity not more than 70 % observing the following procedure.

3.3.1.1 Put the device in a sachet made of 300 µm thick polyethylene film according to ГОСТ 10354-74. Together with the device put the receptacle 2PMT22KПЭ10Г1B1B wrapped up in parchment paper that can be found in a cardboard section, two bags with silicagel (200±5) g each according to ГОСТ 3956-76. Bags should be separated with the carton separator.

3.3.1.2 Weld the sachet providing hermiticity of the package.

Visually control the integrity of sachets and joint welds. The joint weld cannot have punctures, faulty fusions, bubbles, overburnings.

3.3.1.3. Place the sachet into the box with cardboard bumpers, and fix with the inside cover.

3.3.2 The package can be subject to reconservation twice.

The content of moisture in silicagel should not exceed 2 %. Silicagel should be dried on metal sheets not thicker than 5 mm at 200 to 250 °C temperature in drying stoves or special drying machines for 3-5 hours.

The period of long-term preservation is 5 years.

3.3.3 The device is removed from the prolonged storage in the following way:

- take the device from the packing box;
- remove the sachet, take silicagel bags away.

4 REPAIR

4.1 The device is repaired by the producer enterprise at the address:

PE „SPPE "Sparing-Vist Center"

33 Volodymyr Velyky Str.,

Lviv 79026, Ukraine

Tel.: (+38032) 242-15-15, fax: (+38032) 242-20-15.

5 STORAGE

5.1 When the device is placed in storage or removed from storage, the corresponding records should be made in section 13 of the logbook BICT.412129.017-02 ФО.

The device should be stored under the conditions that satisfy the requirements of ГООТ В9.003-80 in heated and unheated storehouses.

5.2 The location of the devices in storehouses should ensure their free movement and access to them.

5.3 The devices should be stored on the shelves.

5.4 The distance between the walls, the floor of the storehouse and the devices should be at least 100 mm.

5.5 The distance between the heating gadgets of the storehouse and the devices should not be less than 0.5 m.

5.6 The average shelf life is not less than 15 years.

5.7 If properly stored and periodic reconservation observed, the storage period of the device may be prolonged for another 5 years.

6 SHIPPING

6.1 Packed devices may be shipped by any kinds of closed transport vehicles according to the requirements of Ж2 category ГОСТ 5150-69, rules and standards effective for each means of transport.

6.2 During shipping of the devices observe handling marks inscribed on the shipping containers.

The devices in shipping container should be placed and fixed in the vehicle to ensure their stable position and to avoid shocks (with each other and the sidewalls of the vehicle).

6.3 The devices in shipping container endure:

- temperature from -50 to $+70$ °C;
- relative humidity of 98 % at $+25$ °C temperature;
- reduced atmospheric pressure of 12 kPa (90 mm Hg).