

**IT-09**  
**DATA PANEL**

**Operating manual**



## CONTENTS

1 DESCRIPTION AND OPERATION.....	2
1.1 APPLICATION OF THE DATA PANEL.....	2
1.2 SPECIFICATIONS.....	3
1.3 DELIVERY KIT OF THE PANEL.....	5
1.4 DESIGN AND THEORY OF OPERATION OF THE PANEL.....	6
1.5 LABELING AND SEALING.....	9
1.6 PACKING.....	9
2 USE OF THE PANEL.....	9
2.1 OPERATING LIMITATIONS.....	9
2.2 PREPARATION FOR OPERATION.....	10
2.3 USE OF THE PANEL.....	11
3 TECHNICAL MAINTENANCE.....	14
3.1 TECHNICAL MAINTENANCE OF THE PANEL.....	14
4 CERTIFICATE OF ACCEPTANCE.....	15
5 PACKING CERTIFICATE.....	15
6 WARRANTY.....	16
7 REPAIR.....	17
8 STORAGE.....	18
9 SHIPPING.....	18
10 DISPOSAL.....	18
APPENDIX A.....	19
APPENDIX B.....	20
APPENDIX C.....	21
APPENDIX D.....	22
APPENDIX E.....	23

This operating manual (the OM) is intended to inform the user about the principles of operation of the IT-09 data panel. The manual contains all information necessary for proper operation of the data panel and full realization of its technical possibilities.

The OM contains the following abbreviations:

DER - ambient dose equivalent rate of gamma and X-ray radiation;  
PC - personal computer.

## **1 DESCRIPTION AND OPERATION**

### **1.1 Application of the data panel**

The IT-09 data panel (hereinafter called the panel) is designed to display the measurement results of ambient dose equivalent rate (DER) of gamma radiation obtained from the BDBG-09 detecting unit of gamma radiation, and to produce audio and light alarm when the DER levels of gamma radiation are exceeded. The panel is also designed to provide the power supply of the BDBG-09 detecting unit of gamma radiation.

The panel coming with the BDBG-09 detecting unit of gamma radiation (hereinafter called the BDBG-09 detecting unit) can be used at the facilities of civil defense, at radiation hazardous sites, and in crowded places (at railway stations, subway stations, supermarkets etc.) to inform the personnel or public about radiation condition of the environment.

The panel belongs to the instruments of information display, and is not the measuring instrument. The measuring instrument is the BDBG-09 detecting unit that is included into the delivery kit of the panel. The number of the BDBG-09 detecting unit (TY Y 33.2-22362867-009:2004) in the State Register for Measuring Instruments is Y2071-05.

## 1.2 Specifications

1.2.1 Key specifications of the panel are presented in the Table 1.1.

Table 1.1- Key specifications of the panel

Name	Unit of measurement	Standardized value according to technical specifications
1 Values display range of gamma radiation DER	$\mu\text{Sv/h}$	$0.01 - 10^7$
2 Amount of digit positions for display of gamma radiation DER value	pc	3
3 Time of operating mode setting, not more than	min	1
4 Time of continuous operation	hour	24 (24-hour continuous mode)
5 Power supply voltage from power adapter <b>Note.</b> Operating supply voltage – 15 V	V	from 12 to 16
6 Current consumption, not more than	A	0.4
7 Dimensions of the panel, not more than	mm	$348 \times 135 \times 40$
8 Length of the connecting cable for connection of the BDBG-09 detecting unit	m	from 10 to 50 (depending on the order)
9 Weight of the panel without the power adapter, the cable and the BDBG-09 detecting unit, not more than	kg	0.95

1.2.2 The possibility of three threshold levels programming in the range of  $0.01 \mu\text{Sv/h}$  to  $9.99 \text{ Sv/h}$  with discreteness of  $0.01 \mu\text{Sv/h}$  is provided in the panel, as well as production of audio alarm of threshold levels exceeding with different soundings for each of the threshold levels and visual alarm – change of the measurement result display color of gamma radiation DER.

1.2.3 Indication of the measured gamma radiation DER is carried out simultaneously and continuously.

1.2.4 The panel meets the following operation requirements:

- air temperature – from - 20 °C to +50 °C;
- relative humidity – up to 95 % at 35 °C, and lower temperatures, non-condensing;
- atmospheric pressure from 84 kPa to 106.7 kPa.

1.2.5 The remote BDBG-09 detecting unit of the panel kit meets the following operation requirements:

- air temperature from - 40 °C to +60 °C;
- relative humidity up to 100 % at +40 °C, and lower temperatures, condensing;
- atmospheric pressure from 84 kPa to 106.7 kPa.

1.2.6 The remote BDBG-09 detecting unit of the panel kit operates in the open air at the distance of up to 50 m from the panel (up to 1200 m at special order).

### 1.3 Delivery kit of the panel

1.3.1 The delivery kit of the panel consists of units and maintenance documentation presented in the Table 1.2.

Table 1.2- Delivery kit

Type	Item	Quantity	Note
BICT.468382.014-07	IT-09 data panel	1	
	Power adapter	1	Model is not specified
BICT.468382.019-07 HE	Operating manual	1	
BICT.418266.008-05	BDBG-09 detecting unit of gamma radiation	1	With corbel
BICT.418266.006-05 HE	Operating manual	1	
BICT.418266.006-05 ΦO	Logbook	1	
BICT.685621.004-01	Connecting cable *	1	from 10 to 50 m
	Mounting parts kit (MPK) **	1	
BICT.411915.003	Packing	1	
* Length of the cable is specified during the order			
** MPK is supplied including: expansion anchor FIX-K-08 KOELNER – 4 pc., screw WPF-4240 KOELNER – 4 pc., expansion anchor FIX with coach screw 10/660 KOELNER – 2 pc., or analogous parts			

## 1.4 Design and principle of operation of the panel

### 1.4.1 Overview

1.4.1.1 The external view of the panel and components of its delivery kit is presented in figures 1, 2 and 3. The panel (according to Figure 1) is designed as a steel dust- and dampproof housing. Ingress protection rating is IP51. All digital and LED indicators and control buttons are located on its front panel.

The splits for connection of the panel to external devices and energizing are located on the right side wall of the panel's housing.

Power supply of the panel is done from the power adapter (Figure 2) that transforms the alternating current of 220 V 50 Hz into the direct current of 15 V.

The BDBG-09 detecting unit (1) with the mounting bracket (4) for fastening to the vertical plane and the connected cable (2) are presented in Figure 3.

### 1.4.2 Design of the panel.

1.4.2.1 The housing of the panel (Figure 1) consists of the tubular profile (1) and two covers: left (2) and right one (3). Four brackets (4) are provided to mount the panel on a vertical plane.

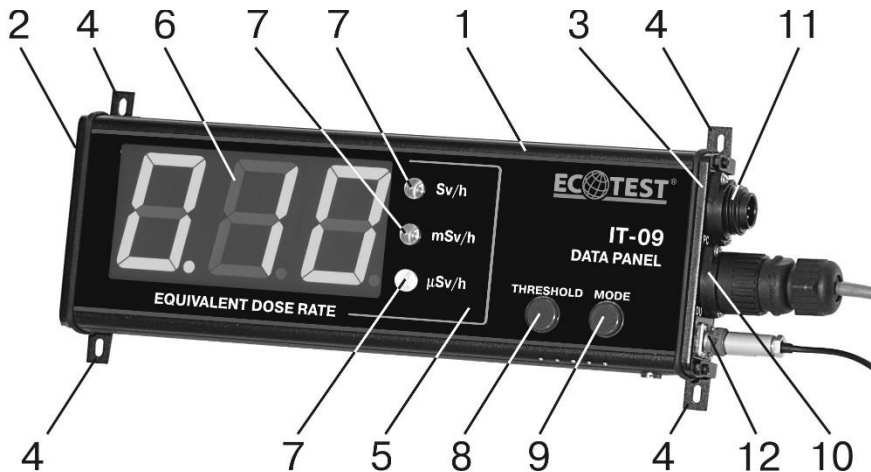

Figure 1 – External view of the panel

On the front panel (5) the following is located:

- digital indicator of measured DER (6) with LED indicators of measurement units (7);
- THRESHOLD (8) and MODE (9) buttons.

On the right rear cover of the panel's housing the split (10) for joining up the connecting cable of the BDBG-09 detecting unit, the split (11) of the PC's connecting cable and the split (12) of the power adapter are located.

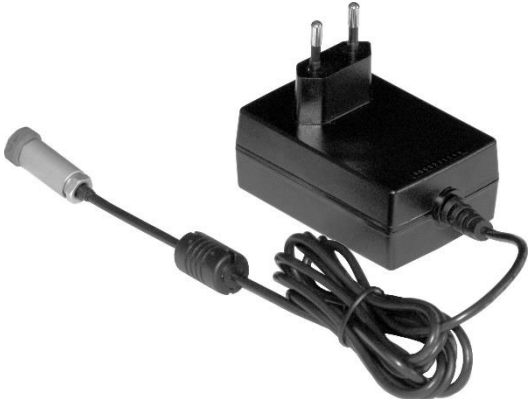

Figure 2 – External view of the power adapter

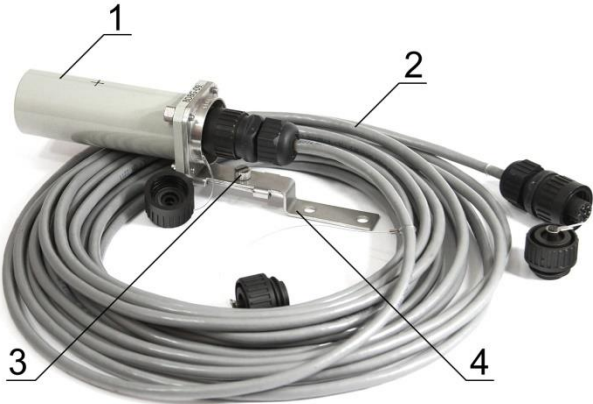

Figure 3 – External view of the detecting unit with the connecting cable

### 1.4.3 Operation of the panel

1.4.3.1 The structure chart of the panel is illustrated in Figure 4. The panel consists of the digital processing circuit (DPC), the digital indicator of measured DER with LED indicators of measurement unit (DI DER), the loudspeaker, the THRESHOLD and MODE buttons, two receivers-transmitters RT1 RS485 and RT2 RS485 of the RS485 interface. The DPC is developed on the basis of the 16-bit microcontroller of the MSP430 series.

The DPC generates the query and receives the measurement results of DER from the BDBG-09 detecting unit via the TR1 RS485. The obtained measurement results are displayed on the DI DER. The DPC also compares DER measurement results with the programmed threshold levels. When a threshold level is exceeded, the DPC produces the sound signal with the help of the loudspeaker. When one threshold level is exceeded the symbols on the DI DER start blinking, and when the second or the third threshold level is exceeded the symbols on the DI DER change the color from green to red.

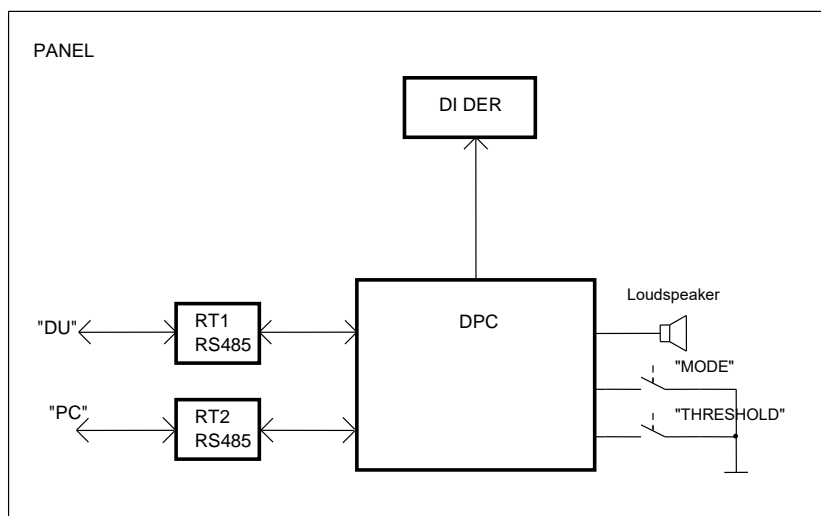

Figure 4 – Structure chart of the panel

## 1.5 Labeling and sealing

1.5.1 The name, design letters, information inscriptions, and the trade mark are inscribed on the front panel of the data panel.

1.5.2 The back wall of the panel's housing is inscribed with the factory serial number and the manufacture date.

1.5.3 Sealing is done by the manufacturer. Special sealing film is placed between the rear cover and the housing of the panel.

1.5.4 Removal of seals and repeated sealing is performed by the manufacturer after repair.

## 1.6 Packing

1.6.1 The panel, the power supply adapter, the BDBG-09 detecting unit with the bracket, the connecting cable, the mounting parts kit and the maintenance documentation for the panel and the BDBG-09 detecting unit are placed into a special packing box.

1.6.2 The cardboard box with the panel kit is placed into the plastic sachet, which is soldered after packing.

## 2 USE OF THE PANEL

### 2.1 Operating limitations

Operating limitations are presented in Table 2.1.

Table 2.1 – Operating limitations

Operating limitation	Parameters
1 Ambient air temperature	from - 20 °C to +50 °C
2 Relative humidity	up to 95 % at 35 °C temperature, non-condensing
3 Photon-ionizing radiation influence	DER up to 100 Sv/h during 5 min

**Note.** Operating limitations for the BDBG-09 detecting unit are outlined in the operating manual of the BDBG-09 detecting unit.

## **2.2 Preparation for operation**

### 2.2.1 External examination procedure

2.2.1.1 Unpack the panel, and check if the delivery kit is complete. Inspect for mechanical damage.

### 2.2.2 Procedure of examination of the panel's readiness for operation

2.2.2.1 Study the operating manual, and examine the control buttons before putting the data panel into operation.

2.2.2.2 Join the power supply adapter to the panel's split, which is marked with the "+15 V". With the help of the cable BICT.685621.004-01 connect the BDBG-09 detecting unit to the panel's split, which is marked with the "DU". Plug in the power adapter into the 220 ( $\pm 22$ )-voltage network. The panel should switch on within 5 s.

### 2.2.3 Mounting the panel kit

2.2.3.1 Mounting of the panel and the BDBG-09 detecting unit and their attachment to concrete and brick walls of the premises is done with the help of the fixing units that are the part of the mounting parts kit. Otherwise attachment is done using the corresponding parts.

2.2.3.2 The panel should be attached to the upright wall in a place, which provides the absence of direct atmospheric precipitations at the distance to the "~ 220 V 50 Hz" power outlet not longer, than the length of the cable from the power supply adapter.

To protect the panel from a negative influence of external electromagnetic interference, provide a secure earthing system of the panel's housing by connecting the external grounding conductor to the grounding terminal.

2.2.3.3 The BDBG-09 detecting unit should be attached to the upright wall at the external side (facia) of the building or in the premises provided that the direct sun rays will not reach it. Before that the bracket should be attached hook up. Then the detecting unit should be placed on it and the connecting cable should be joined.

### 2.2.4 Troubleshooting

2.2.4.1 Troubleshooting is presented in Table 2.2. Troubles during use are recorded in the Appendix C of this OM.

Table 2.2 - Troubleshooting

Trouble	Problem cause	Solution
The panel does not turn on	1 The cable of the power adapter is not connected 2 Cable breakdown of the power adapter	1 Connect up the power adapter to the panel 2 Remove the cable breakdown of the power adapter
“Er1” notification on the DER indicator	The high-sensitive counter of the BDBG-09 detecting unit is out of order	Replace the high-sensitive counter of the BDBG-09 detecting unit
“Er2” notification on the DER indicator	The low-sensitive counter of the BDBG-09 detecting unit is out of order	Replace the low-sensitive counter of the BDBG-09 detecting unit
“Er3” notification on the DER indicator	1 The BDBG-09 detecting unit is not connected to the panel 2 The connecting cable between the panel and the BDBG-09 detecting unit is damaged 3 The BDBG-09 detecting unit is out of order	1 Connect the BDBG-09 detecting unit to the panel 2 Replace the connecting cable 3 Replace the BDBG-09 detecting unit

2.2.4.2 At failure to eliminate the troubles presented in the Table 2.2 or at detection of more complicated troubles, the panel should be sent for repair to the repair services to the manufacturer.

## 2.3 Use of the panel

### 2.3.1 Safety measures during use of the panel

2.3.1.1 The panel should be used in line with the valid regulatory documents.

2.3.1.2 The surface of the panel contains no voltages that may pose threat to life.

2.3.1.3 The protective shielding is used to avoid accidental contact with the current-conducting parts.

The ingress protection rating is IP51.

2.3.1.4 The panel belongs to fire safety equipment.

2.3.1.5 The panel is not dangerous for the maintenance personnel and is environmentally friendly.

2.3.1.6 In case of contamination with radioactive substances, the panel should be deactivated. Wipe its surface by a gauze tampon moistened by the standard decontaminating agent.

2.3.1.7 Disposal of the panel is performed in compliance with the general rules, i.e. metals are recycled or melted, and plastic parts are dumped.

### 2.3.2 Operating modes of the panel

The panel operates within the following modes:

- indication of the measured gamma radiation DER;
- threshold levels viewing;
- values change of the threshold levels;

### 2.3.3 Operating procedure

After the panel is turned on, it always starts working in the mode of indication of the measured gamma radiation DER.

To proceed to the threshold levels viewing mode, press the THRESHOLD button and release it (in about 8-10 seconds) after the green “TL.X” symbols appear on the DER indicator, where “X” is a blinking figure from 1 to 3 (threshold level number). Short presses of the THRESHOLD button change the number of the threshold level per 1, and a short press of the MODE button displays the value of that threshold level on the DER indicator. Indication of the DER value continues till the MODE button is pressed again.

If the button is not pressed for 10 s in this mode, the panel finishes the mode of threshold levels viewing and turns back to the display mode of the measured gamma radiation DER.

To pass on to the mode of threshold levels change, simultaneously press and hold for about 10 s. the THRESHOLD and MODE buttons until the red “TL.X” symbols appear on the DER indicator, where “X” is a blinking figure from 1 to 3 (threshold level number). Release the buttons. Next short presses of the THRESHOLD button change the number of the threshold level per 1, and a short press of the MODE button changes the value of that level. The least significant digits of the threshold level value are displayed on the DER indicator, and the least significant digit of the DER indicator is blinking. This shows that the value of the digit position can be changed.

The threshold level can be changed in the following way. Successive short presses and releases of the THRESHOLD button change the value of the blinking digit position per one. Short press of the MODE button fixes the value of the blinking digit and the next digit starts blinking, which makes it possible to change it. After the first three figures of the threshold level value are entered, the figures on the DER indicator begin shifting from left to right, and the major digit positions of the threshold level value can be entered.

After the value of the major figure is entered, the “SAV” symbol shortly appears on the DER indicator. This shows that a new value of the threshold level is saved in the nonvolatile memory. Then the red colored “TL.X” symbol is displayed on the DER indicator again, so that the value of other threshold levels may be changed.

Programming of values of the other threshold levels is done the same way in line with the abovementioned procedure.

To quit the mode of the threshold level values change, simultaneously press and release the THRESHOLD and MODE buttons.

If the buttons are not pressed within 80 s in the mode of the threshold level values change, the panel terminates the mode and turns back to the mode of indication of the measured gamma radiation DER.

**Note.** When the panel is turned on for the first time the threshold level values are the following: TL.1 –0.3  $\mu\text{Sv/h}$ ; TL.2 –1  $\mu\text{Sv/h}$ ; TL.3–3  $\mu\text{Sv/h}$ . If the threshold level values are preset as zero values, the threshold alarm will be turned off. When the panel is placed into operation the threshold levels should be set according to the regulatory documents or other requirements.

### 3 TECHNICAL MAINTENANCE

#### 3.1 Technical maintenance of the panel

##### 3.1.1 General instructions

The list of operations performed during technical maintenance (hereinafter the TM) of the panel, the order and peculiarities of operational phases are given in Table 3.1.

Table 3.1 - List of operations during technical maintenance

Operations	TM type			OM item No.
	during		during long-term storage	
	everyday use	periodical use		
External examination	+	+	+	3.1.3.1
Delivery kit completeness check	-	+	+	3.1.3.2
Operability check	+	+	+	3.1.3.3
<b>Note.</b> “+” means the operation is applicable at this type of TM, “-” means the operation is not applicable				

##### 3.1.2 Safety measures

TM safety measures fully comply with safety measures stated in item 2.3.1 of the present OM.

##### 3.1.3 Maintenance procedure of the panel

###### 3.1.3.1 External examination

External examination of the panel should be performed in the following order: check the technical condition of the component parts surface, inspect for integrity of seals, absence of scratches, traces of corrosion, and surface damage of the panel.

###### 3.1.3.2 Delivery kit completeness check

Check if the delivery kit is complete according to Table 1.2.

###### 3.1.3.3 Operability check of the table

3.1.3.3.1 Operability check of the data panel is done according to item 2.3.3 of the present the OM.

#### 4 CERTIFICATE OF ACCEPTANCE

The IT-09 data panel of BICT.468382.019-07 type with \_\_\_\_\_ serial number together with the other component parts of the delivery kit is accepted for use.

Date of issue \_\_\_\_\_

QCD Representative: \_\_\_\_\_

(signature)

Stamp here

#### 5 PACKING CERTIFICATE

The IT-09 data panel of BICT.468382.019-07 type with \_\_\_\_\_ serial number together with the other component parts of the delivery kit is packed by the PE "SPPE "Sparing-Vist Center" in accordance with the requirements outlined in the OM.

Date of packing \_\_\_\_\_

Stamp here

Packed by \_\_\_\_\_

(signature)

## **6 WARRANTY**

6.1 The manufacturer guarantees the conformity of the data panel to the technical requirements provided that the customer observes the guidelines for its use, shipping and storage presented in the operating manual BICT.468382.019-07 HE.

6.2 The warranty period of the panel shall terminate and be of no further effect in 24 months after the date of putting it into operation or after the warranty period of storage terminates.

6.3 The warranty period of storage of the panel is 6 months after its manufacture date.

6.4 The warranty period of use of the panel is prolonged for the period of the warranty repair.

6.5 After the warranty period of the panel terminates, its repair is performed according to separate contracts.

6.6 Warranty and post-warranty repair is done only by the manufacturer.

6.7 If the mechanical damage is detected or seals are removed, repair is done at customer's cost.

## 7 REPAIR

7.1 In case of failure or troubles during the warranty period of the panel, the user should contact the enterprise producer by e-mail (see below) to receive the address of the nearest service center:

***PE "SPPE "Sparing-Vist Center"***  
***Tel.: (+380 32) 242-15-15; Fax: (+380 32) 242-20-15;***  
***E-mail: sales@ecotest.ua.***

7.2 All claims are registered in Table 7.1.

Table 7.1

Date of failure	Claim summary	Action taken	Note

7.3 Warranty and post-warranty repair should be done only by the manufacturer. Information about repair of the data panel is recorded in the table of the Appendix D of this OM.

## **8 STORAGE**

8.1 The panels should be stored in a packing box in heated and ventilated storehouses with air-conditioning at the ambient air temperature from +5 °C to +40 °C and relative humidity up to 80 % at +25 °C temperature, non-condensing. The storehouse should be free of acids, alkali and gases that may cause corrosion, and vapors of organic solvents.

8.2 The location of the panels in storehouses should ensure their free movement and free access to them.

8.3 The panels should be stored on the shelves.

8.4 The distance between the walls, the floor of the storehouse and the panels should be at least 0.5 m.

8.5 The distance between the heating gadgets of the storehouse and the panels should be at least 0.5 m.

8.6 The average shelf life is not less than six months.

8.7 Additional information on storage, check during storage and maintenance of the panels is recorded in Appendices A, B, E of this OM.

## **9 SHIPPING**

9.1 Packed panels may be shipped by any kind of closed transport vehicles under the conditions with temperature limitation in the range of - 25 to + 55 °C, and according to rules and standards effective for each means of transport.

9.2 The panels in shipping container should be placed and fixed in the vehicle to ensure their stable position and to avoid shocks (with each other and the sidewalls of the transport).

9.3 The panels in shipping container endure:

- temperature from -25 to +50 °C;
- relative humidity (95±3) % at 35 °C temperature.

9.4 Canting is forbidden.

## **10 DISPOSAL**

Disposal of the panels is performed in compliance with the general rules, i.e. metals are recycled or melted, and plastic parts are dumped..

Disposal of the panel is not dangerous for service personnel, and is environmentally friendly.

**APPENDIX A**

**PUTTING IN PROLONGED STORAGE AND REMOVAL FROM STORAGE**

Date of putting in prolonged storage	Storage method	Date of removal from prolonged storage	Name of the enterprise in charge of putting or removing from prolonged storage	Date, position and signature of the responsible person

**APPENDIX B**  
**STORAGE**

Date		Storage conditions	Position, name and signature of the responsible person
of placing in storage	of removing from storage		

## APPENDIX C

### TROUBLE RECORD DURING USE

Date and time of failure. Operating mode	Type (manifestation) of trouble	Cause of trouble, number of operation hours of the failed element	Action taken and claim note	Position, name and signature of the person responsible for solving the problem	Note

## APPENDIX D

### REPAIR

Name and type of the component part of the panel	Reason for repair	Date		Name of the repair organization	Number of operation hours before repair	Type of repair	Name of repair	Position, name and signature of the responsible person	
		of arriving for repair	of repair completion					who performed repair	who accepted after repair

## APPENDIX E

### VERIFICATION AND INSPECTION RESULTS

Date	Verification or inspection type	Verification or inspection result	Position, name and signature of the person responsible for inspection	Note