

# GAMMA RADIATION ALARM UNIT

**BS-09**

**Operating Manual**  
**BICT.468382.057-02 HE**





# CONTENTS

1 DESCRIPTION AND OPERATION.....	3
1.1 PURPOSE OF USE OF BS-09 GAMMA RADIATION ALARM UNIT .....	3
1.2 SPECIFICATIONS .....	4
1.3 DELIVERY KIT OF BS-09 UNIT.....	8
1.4 DESIGN OF BS-09 UNIT AND PRINCIPLE OF ITS OPERATION.....	9
1.5 OPERATION OF BS-09 UNIT .....	10
1.6 LABELING .....	11
1.7 PACKAGING .....	11
2 PROPER USE .....	12
2.1 PREPARATION OF THE BS-09 UNIT FOR OPERATION .....	12
2.2 RULES AND PROCEDURE OF EXAMINATION OF THE BS-09 UNIT FOR OPERATIONAL READINESS .....	12
3 TECHNICAL MAINTENANCE .....	27
3.1 TECHNICAL MAINTENANCE OF THE BS-09 UNIT.....	27
4 CERTIFICATE OF ACCEPTANCE .....	29
5 PACKING CERTIFICATE.....	29
6 WARRANTY.....	30
7 REPAIR .....	31
8 SHIPPING AND STORAGE.....	32
9 DISPOSAL.....	33
ANNEX A TROUBLE RECORD DURING USE .....	34
ANNEX B REPAIR OF BS-09 UNIT .....	35
ANNEX C STORAGE.....	36
ANNEX D PUTTING IN PROLOGED STORAGE AND REMOVAL FROM STORAGE DURING USE OF BS-09 UNIT .....	37
ANNEX E VERIFICATION AND INSPECTION RESULTS.....	38
ANNEX F INSTRUCTIONS FOR USING THE “TEO SYSTEM” TECHNOLOGICAL PROGRAM .....	39
ANNEX G INSTRUCTIONS FOR USING THE WEB INTERFACE OF THE BS-09 UNIT.....	42
ANNEX H COMMUNICATIONS PROTOCOL OF THE DATA DISPLAY SYSTEM AND BS-09 UNIT .....	48
ANNEX J .....	88
ANNEX K COMMENDATIONS FOR CABLE CHOICE FOR CONNECTING THE BDBG-09 DETECTING UNIT TO THE BS-09 UNIT AND FOR CONNECTING THE BS-09 UNIT TO THE INFORMATION COLLECTION AND DISPLAY SYSTEM VIA RS-485 INTERFACE .....	90
ANNEX L COMMENDATIONS FOR CABLE CHOICE FOR CONNECTING THE BS-09 UNIT TO THE INFORMATION COLLECTION AND DISPLAY SYSTEM VIA ETHERNET INTERFACE.....	92
ANNEX M .....	93
ANNEX N.....	94
ANNEX P .....	95
SPECIAL NOTES.....	96

This operating manual (OM) is intended to inform the user about the principle of operation of BS-09 gamma radiation alarm unit, the procedure for working with it and contains all the data necessary for full application of its technical capabilities and its proper use.

The OM includes the following abbreviations and symbols:

DER – ambient dose equivalent rate of gamma radiation;

THD1 – warning threshold level;

THD2 – safety threshold level;

PoE – power over Ethernet, technology of electricity and data transmission using “twisted pair”;

PC – personal computer;

TS (TY) – technical specification.

## 1 DESCRIPTION AND OPERATION

### 1.1 Purpose of use of BS-09 gamma radiation alarm unit

BS-09 gamma radiation alarm unit (hereinafter referred to as the BS-09 unit), which is intended for light and sound notification of personnel about the levels of gamma radiation at radiation-hazardous facilities, as well as indication of the local value of radiation background measured by the BDBG-09 gamma radiation detecting unit or similar one (hereinafter – the detecting unit). The BS-09 unit is installed together with the gamma radiation detecting unit and allows notifying the personnel working in close proximity to the detecting units in case of possible radiation threat.

#### **The BS-09 unit does not belong to the measuring equipment.**

The BS-09 unit belongs to the automation hardware (AH) of information systems of normal service safety class 3 (classification mark 3H) in accordance with НП 306.2.141 standardized document, seismic category II, installation height up to 25 m.

The BS-09 unit according to the functions it performs and which affect safety, belongs to category C in accordance with НП 306.2.202-2015.

The BS-09 unit can be used in the following areas:

- nuclear power plants;
- oil and gas industry;
- railways;
- radioactive waste storage facilities;
- industry.

The BS-09 unit uses a microcontroller that allows you to irreversibly block access to firmware by destroying protection bits during programming. This ensures that the firmware is protected from unauthorized interference.

## 1.2 Specifications

1.2.1 Key specifications and data are presented in Table 1.

Table 1

Specification	Unit of measure	Standardized values
Indication range of gamma radiation DER (hereinafter – photon-ionizing radiation)	Sv/h	from $1 \cdot 10^{-8}$ to 99.9
Programming range of threshold levels signaling exceeding photon-ionizing radiation DER	Sv/h	from $1 \cdot 10^{-8}$ to 99.9
Supply voltage of BS-09 unit when powered via an Ethernet connector using PoE technology	V	25 ... 60
Supply voltage of BS-09 unit when powered from the external power supply unit via a separate connector and from the mains using RS-485 connector	V	from 12 to 32
Output voltage to power the external detecting unit	V	$12.0 \pm 1.2$
BS-09 unit provides self-contained operation from the built-in Li-ion battery with recording of measurement history of photon-ionizing radiation DER by the external detecting unit in steps of 5 min, minimum	hour	24
Maximum power consumption with connected external detecting unit, not more than	W	7,5
Volume level of the light and sound alarm unit	dB	80
Operating temperature range	°C	from -20 to +50
Dimensions of BS-09 unit, not more than	mm	181×230 ×81
Weight of BS-09 unit, not more than	kg	1.2
Distance between the BS-09 unit and the detecting unit, not more than	m	0.5

1.2.2 The BS-09 unit features a threshold alarm system with two threshold levels of photon-ionizing radiation DER:

- threshold level THD1 (warning threshold level);
- threshold level THD2 (safety threshold level).

1.2.3 The threshold alarm of the BS-09 unit when the threshold levels THD1 or THD2 are exceeded is triggered immediately after receiving the results from the detecting unit.

Once triggered, the user can turn off the sound alarm by pressing any button, or remotely, using a command from external devices.

1.2.4 The BS-09 unit can exchange information with external devices via interfaces: RS-485 (protocols: “modbusRTU” and special “Ecotest”), Ethernet (protocols: “modbusTCP”, “HTTP” and special “Ecotest”).

1.2.5 Average time to failure (hereinafter – failure-free operation) of the BS-09 unit is not less than 10,000 hours.

The failure criterion of the detecting unit – is non-compliance with the requirements 1.2.1 ... 1.2.4.

1.2.6 The average service life of the BS-09 unit is not less than 10 years.

The criterion of the limit condition of the detecting unit is the impossibility or inexpediency of repair.

1.2.7 The average recovery time of the BS-09 unit is not more than 2 hours, if the necessary components are available.

1.2.8 The average shelf life – not less than 10 years, if the battery is recharged every 6 months after the start of storage.

1.2.9 The BS-09 unit remains operable under the following conditions:

- operating air temperature – from minus 20 °C to +50 °C, limit – up to +60 °C;
- rate of temperature change – not faster than 5 °C/h;
- operating relative humidity – from 20 % to 75 % at a temperature of 50 °C and lower temperatures, non-condensing, limit – steam-gas mixture at a temperature of 60 °C;
- operating atmospheric pressure – from 86 kPa to 108 kPa, limit -130 kPa.

Impact of limiting operating conditions - up to 3 hours.

1.2.10 The BS-09 unit is resistant to sinusoidal vibrations in the frequency range from 1 Hz to 150 Hz (transition frequency – 10 Hz), offset for the frequency below the transition frequency of 0.75 mm and acceleration for the frequency above the transition frequency of 2 m/s<sup>2</sup>. Impact direction – Z (along the vertical axis of the product).

1.2.11 The BS-09 unit is resistant to single shocks with the following parameters:

- shock pulse duration – 100 ms;
- number of shocks - 1000±10;
- maximum shock acceleration – 40 m/s<sup>2</sup>;
- impact direction – Z.

1.2.12 The BS-09 unit during transportation is resistant to shocks with an acceleration of  $98 \text{ m/s}^2$ , the duration of the shock pulse of 16 ms and the number of shocks –  $1000 \pm 10$ .

1.2.13 The BS-09 unit must be resistant to ionizing gamma radiation with an absorbed dose rate of 0.15 mGy/h and an absorbed dose of 13 Gy for 10 years.

1.2.14 The BS-09 unit is resistant to vibration caused by a 7.0 strength level earthquake according to the scale MSK-64 ДСТУ-Н Б В.1.1-28 (seismic category II, installation height up to 25 m).

1.2.15 The BS-09 unit meets the performance quality criteria in accordance with DSTU EN 61326-1:2016 during noise immunity tests.

1.2.15.1 The BS-09 unit is resistant to static electrical discharges (degree of rigidity 3 – according to SOU NNEGC 100:2016).

1.2.15.2 The BS-09 unit is resistant to interference from rapid transients/pulse packets (degree of rigidity 3 – according to SOU NNEGC 100:2016).

1.2.15.3 The BS-09 unit is resistant to the influence of radio frequency electromagnetic fields of emission (degree of rigidity 3 – according to SOU NNEGC 100:2016).

1.2.15.4 The BS-09 unit is resistant to long-term magnetic fields of industrial frequency 50 Hz (degree of rigidity 4 according to SOU NNEGC 100:2016).

1.2.15.5 The BS-09 unit is resistant to short-term magnetic fields of industrial frequency 50 Hz (degree of rigidity 4 according to SOU NNEGC 100:2016).

1.2.15.6 The BS-09 unit is resistant to pulsed magnetic fields (degree of rigidity 4 according to SOU NNEGC 100:2016).

1.2.15.7 The BS-09 unit is resistant to the influence of the attenuating oscillating field (degree of rigidity 4 according to SOU NNEGC 100:2016).

1.2.15.8 The BS-09 unit is resistant to attenuating oscillating interference (degree of rigidity 3 according to SOU NNEGC 100:2016).

1.2.15.9 The BS-09 unit is resistant to interference from surges of voltage and current (microsecond pulse interference in power supply circuits, degree of rigidity 3 according to SOU NNEGC 100:2016).

1.2.15.10 The BS-09 unit is resistant to conductive interference caused by radio frequency fields (degree of rigidity 3 according to SOU NNEGC 100:2016).

1.2.15.11 The BS-09 unit is resistant to conductive asymmetric interference (degree of rigidity 3 according to SOU NNEGC 100:2016).

1.2.15.12 The BS-09 unit is resistant to interference in ground lines (microsecond pulse interference and short-term sinusoidal interference, degree of rigidity 3 according to SOU NNEGC 100:2016).

1.2.16 The quasi-peak value of the radio interference field strength from the BS-09 unit does not exceed the values established for Class A equipment in accordance with DSTU EN 55011:2019.



1.2.17 The BS-09 unit is resistant to decontamination by one of the decontamination solutions:

- a) oxalic acid – 10 g/dm<sup>3</sup>;
- b) 5% solution of citric acid in ethyl alcohol C<sub>2</sub>H<sub>5</sub>OH (density 96 %);
- c) boric acid – 16 g/l;
- d) Na<sub>2</sub>S<sub>2</sub>O<sub>3</sub>·5H<sub>2</sub>O – 1% solution;
- e) synthetic detergents such as “Novyna”, ОП-7, ОП-10 (from 7 to 10 g per 1 dm<sup>3</sup> of water).

1.2.18 Protection against unauthorized access to the BS-09 unit is provided by sealing, which prevents penetration into its interior.

1.2.19 Requirements for the firmware of the BS-09 unit

1.2.19.1 Firmware provides continuous self-testing of the BS-09 unit.

1.2.19.2 The BS-09 unit provides protection for firmware against unauthorized interference.

1.3 Delivery kit of BS-09 unit

Delivery kit of the BS-09 unit consists of the items and maintenance documentation presented in Table 2.

Table 2 – Delivery kit

Type	Item	Quantity
BICT.468382.057-02	BS-09 unit	1
BICT.468382.057-02 HE	Operating manual	1
	Declaration of Conformity to the Technical Regulations on Electromagnetic Compatibility**	1
BICT.468936.005-02	Package	1
BICT.468931.002	Installation kit (IK) *: _____	1 _____

\* IK products are used by the consumer to fix the BS-09 unit at the installation site and when making connecting cables for connection to the system, to the detecting unit and the power supply.

It is possible to manufacture and supply connecting cables of the required length to the consumer optionally.

The list and quantity of products are determined by the consumer depending on the configuration of use of the BS-09 unit.

Products are delivered if they are specified in the Supply Agreement.

\*\* One copy per batch of BS-09 units is supplied

## 1.4 Design of BS-09 unit and principle of its operation

### 1.4.1 General information, description of the design

The appearance of BS-09 unit is shown in Figure 1.



Figure 1 – Appearance of BS-09 unit

Structurally, the BS-09 unit is designed as a rectangular parallelepiped. The case is aluminum and dust & damp-proof. The working position of the BS-09 unit is vertical.

The housing consists of a base (1) and a front panel (2), connected by screws. On the front panel (2) there is a window of liquid crystal character display (3), windows of LED indicators “ETHERNET”, “RS-485”, “DC”, “DC RESERVE”, buttons “THRESHOLD/INPUT” (4) and “MODE”. (5). At the bottom of the panel there is information about the connectors located on the bottom wall of the case. On the upper wall of the case there is a light and sound alarm device (6), on the lower wall of the case there are connectors “RS-485 OUT”, “RS-485 IN”, “ETHERNET”, “DC IN”. Connectors in a non-working state are closed by protective caps (not shown on the picture).

The ground terminal is located on the right wall of the housing. There is an engraving of the serial number of the BS-09 unit, the manufacture date and an information plate of the BS-09 unit on the right wall.

Flanges with four openings for securing the BS-09 unit in the operating position are made on the basis of the case.

The BS-09 unit is sealed with mastic in the recess of one of the screws for mounting the front panel.

### 1.5 Operation of BS-09 unit

The principle of operation of BS-09 unit is to read measurements from the detecting unit, transmit the received data via two interfaces RS-485 (protocols (Annex H): “modbusRTU” and special “Ecotest”) and Ethernet (protocols (Annex H): “modbusTCP” and special “Ecotest”). The BS-09 unit allows you to set two threshold levels to signal the exceeding of these threshold levels and reports about that with light and sound alarms.

#### 1.5.1 Operating modes of BS-09 unit

The BS-09 unit has the following operating modes:

- the main operation mode;
- backup power mode.

The BS-09 unit has the following display modes:

- indication of photon-ionizing radiation DER;
- setting the threshold levels;
- time and date.

#### 1.5.2 Two buttons are used to control the operation of BS-09 unit:

- The “MODE” button allows navigating the menu and change the display mode of photon-ionizing radiation DER, adjusted threshold levels and time and date.

- The “INPUT” button allows confirming/cancelling changes, increment the number, enter the appropriate menu item, open the PIN input menu.

1.5.3 A liquid crystal character display (hereinafter referred to as the display) is used to monitor the operation of BS-09 unit.

1.5.4 During operation, the BS-09 unit generates the following sound and light signals:

- exceeding the warning and safety threshold levels – periodic light and sound signals that are generated if the measured value of photon-ionizing radiation DER becomes greater than the set threshold levels;

- in case of disconnection from the detector – periodic red light signals;

- when the display is switched on in the backup power mode, an audible signal is sounding while it is on.

## 1.6 Labeling

1.6.1 Labeling of the BS-09 unit meets the requirements of the Design Documentation (DD) set in accordance with BICT.468382.057-02 and contains:

- trademark of the manufacturer;
- name of the BS-09 unit;
- serial number and manufacture date according to the numbering system of the manufacturer;
- TU mark;
- ingress protection rating in accordance with DSTU EN 60529:2018;
- mark of compliance with technical regulations.

Labeling of serial number and manufacture date is performed by engraving.

The labeling is resistant to external factors specified in 1.2.9... 1.2.14, 1.2.17 of this OM, except for labeling made on individual packaging.

1.6.2 The BS-09 unit, accepted by the Quality Control Department (QCD) and prepared for packaging, shall be sealed.

1.6.3 Labeling of transport packaging meets the requirements of GOST 14192-96 standard and contains the main (name of consignee and destination), additional (name of consignor and point of origin) and information (gross and net weight in kg) inscriptions, as well as handling marks No.1, No.3, No.11.

The labeling of type of the BS-09 unit and quantity of units in a box in pieces is made under the main inscriptions.

Sizes of fonts and handling marks are selected based on the sizes of the selected boxes.

Labeling is applied directly to the container. Materials for labeling are selected from the list recommended by GOST 14192-96 standard.

## 1.7 Packaging

1.7.1 The BS-09 unit is packed in a cardboard box according to the DD set for packaging BICT.468936.005.

1.7.2 During transportation, packed BS-09 units are placed in unitized transport containers (containers, cases, boxes), which meet the requirements for transportation set out in 15.1... 15.5.

The total weight of the units in the unitized transport packaging shall not exceed 12 kg.

Transport packaging provides protection against unauthorized access to packed BS-09 units, packaging shall be sealed by a QCD representative of the manufacturer.

**Note.** The BS-09 units can be sent in individual packaging by postal parcels in compliance with the rules established by the Ministry of Infrastructure of Ukraine.

## 2 PROPER USE

### 2.1 Preparation of the BS-09 unit for operation

#### 2.1.1 Scope and order of the external examination

Before using the BS-09 unit, unpack it and check if the delivery kit is complete.

Examine for mechanical damages

#### 2.1.2 Operating restrictions

Operating restrictions are shown in Table 3.

Table 3 - Operating restrictions

Operating restriction	Restriction parameter
Ambient air temperature	below from - 40 to above + 75 °C
Relative humidity	above 98 % at + 50 °C temperature, non-condensing
Impact of photon-ionizing radiation	Impact of photon-ionizing radiation more than 100 Sv/h for 5 minutes

### 2.2 Rules and procedure of examination of the BS-09 unit for operational readiness

2.2.1 Study the operating manual before starting work. Study the location and purpose of the connectors, light and sound alarm device and controls.

2.2.2 The BS-09 unit shall be mounted on a vertical wall next to the detecting unit by means of an installation kit included in the delivery kit, and the detecting unit and external devices shall be connected to it by means of connecting cables in accordance with the requirements at the facility of application.

Typical circuits of power connection and connection to the external information processing system to the BS-09 are provided in Annexes M, N, P. Recommendations for the choice of cables are given in Annexes K and L.

### 2.3 Application of the BS-09 unit

#### 2.3.1 Safety measures when using the BS-09 unit

2.3.1.1 All works with sources of ionizing radiation during the tests of the BS-09 unit shall be carried out in accordance with the requirements of DGN 6.6.1-6.5.001-98 and DSP 6.177-2005-09-02.

2.3.1.2 General safety requirements during testing and operation of the BS-09 unit shall comply with the requirements of DSTU 7237:2011 standard.

2.3.1.3 According to the protection method against electric shock hazard the BS-09 unit is made in accordance with DSTU EN 61010-1:2014 standard.

**Note.** The class of protection against electric shock is not determined due to the external supply voltage of the BS-09 unit being less than 60 V.

2.3.1.4 A protective shell is used to provide protection against accidental contact with live parts in the BS-09 unit. The ingress protection rating is IP65 in accordance with DSTU EN 60529:2018.

2.3.1.5 The insulation between the conductive elements on the housing of the BS-09 unit and the insulated electrical sections is resistant under the influence of AC test voltages with a frequency of  $(55\pm 10)$  Hz with an amplitude value of 500 V at 50 °C and a relative humidity of 75% and an amplitude value of 300 V at a temperature of 60 °C and gas-vapor mixture.

The insulation resistance of the above sections at a voltage of 500 V is:

- under normal conditions – not less than 40 MΩ;
- at a temperature of 50 °C – not less than 10 MΩ;
- at a relative humidity of 75% at a temperature of 50 °C – not less than 2 MΩ.

2.3.1.6 Disposal of the BS-09 unit shall be carried out in accordance with DSTU 4462.3.01:2006, DSTU 4462.3.02:2006, the Laws of Ukraine “On Environmental Protection” and “On Waste”.

**Note.** In case of contamination of the BS-09 unit with liquid or bulk substances containing radionuclides and impossibility of its decontamination, the BS-09 unit shall be disposed of as solid radioactive waste.

2.3.1.6 Fire safety during the use, storage, transportation of BS-09 units must comply with the requirements of DSTU 8828 and NAPB A.01.001 document.

The probability of fire does not exceed  $10^{-6}$  per year.

## 2.4 Operating procedure with the BS-09 unit

### 2.4.1 Switching the BS-09 unit on

To switch on the BS-09 unit, you must supply power using one of the following options provided for at the application site:

- connect the BS-09 unit with an Ethernet cable to a device with PoE support (hereinafter – PoE power supply);
- connect the BS-09 unit to the power adapter or cable with RS-485, which provides DC power from 12 V to 32 V.

**IMPORTANT!** When powered using PoE, the latter may not be initialized if external power supply units are connected to the “DC IN” and “RS-485” connectors. This happens because the presence of a connected external loop creates additional capacitance, which prevents PoE initialization. To start PoE correctly, disconnect external devices and wait until the device initializes.

After switching on, the BS-09 unit checks the integrity of the firmware. If a discrepancy is detected, the operation of the BS-09 unit is stopped (display off, “DC” LED on).

If examination of the firmware integrity is successful, the BS-09 unit continues the self-test. The display will first show the name of the BS-09 unit and its serial number (Figure 2), followed by information about the software and hardware version (Figure 3).



Figure 2 – Information about BS-09 unit



Figure 3 – Software and hardware version of BS-09 unit

After that, the BS-09 unit sends queries to the connected detecting unit, and the display shows the current level of photon-ionizing radiation DER (hereinafter – DER). If the battery was discharged, its charging process begins and the current battery level is displayed next to the current DER level. If the results obtained from the detecting unit are inaccurate<sup>1</sup>, the DER value flashes. If there is no connection with the detecting unit, an “Err 1” error message appears on the display.

#### 2.4.2 Switching the BS-09 unit off

To turn off the BS-09 unit, if it is not going to be powered from external power sources, you shall enter the settings menu, turn on the transport mode, after the inscription “Transport Mode Enabled” appears return to the main menu and turn off the power.

**IMPORTANT!** The next time you switch it on, the transport mode will be switched off, so if you need to switch off the BS-09 unit, you must switch the transport mode on again.



Figure 4 – Switching Transport Mode on

---

<sup>1</sup> The measurement result is considered unreliable if the statistical measurement error exceeds the maximum permissible measurement error of the detecting unit.



### 2.4.3 Display modes of DER, set threshold levels and time and date.

After switching on, the BS-09 unit proceeds to the DER display mode.

A short press of MODE button switches the BS-09 unit to the display mode of the set threshold levels. The next press of MODE button switches the BS-09 unit to the date and time display mode (must be configured using the settings menu 2.4.4 or via the web interface of the BS-09 unit).

Display modes of DER, set threshold levels and time and date belong to the main menu.

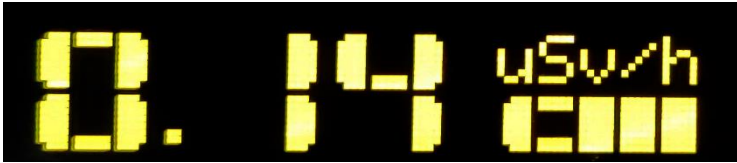

Figure 5 – DER readings display mode when the detecting unit is connected

If there is no connection with the detecting unit, an error message appears on the display and the light indicator flashes red.



Figure 6 – DER readings display mode when communication with the detecting unit is lost

If the results obtained from the detecting unit are inaccurate, the obtained DER values will flash with a period of 2 s.

The DER display window (Figures 5, 6) displays the following information: the current DER level and its measurement unit, the current battery level.



– display of the current battery level during charging.

After pressing the MODE button, the BS-09 unit switches to the display mode of the set threshold levels THD1 and THD2 (Figure 7).



Figure 7 – Display mode of the set threshold levels THD1 and THD2

The next time you press MODE button, the BS-09 unit switches to the time and date display mode (Figure 8).



Figure 8 – Time and date display mode

#### 2.4.4 BS-09 unit setting mode

To enter the setting mode, press INPUT button in the main menu and enter the PIN code (Figure 9).



Figure 9 – Entering the PIN code

When you press the MODE button you switch between the fields of PIN input and confirmation or cancellation.

Pressing the INPUT button on the corresponding PIN input field<sup>2</sup> will increment this figure, confirm or cancel the action.

**IMPORTANT!** Do not pass on the PIN code to enter the settings to persons who do not have the authority to do so.

The menu of the BS-09 unit setting mode includes the following items:

---



<sup>2</sup> Input field - highlighted with cursor or underlined characters.

- Threshold 1 – warning threshold settings,
- Threshold 2 – safety threshold settings,
- Sound – sound alarm settings,
- Language – select the language for data presentation on the BS-09 unit display,
- Internet – change the settings that are responsible for connecting to the BS-09 unit via Ethernet cable,
- Relay settings – change the relay settings, which is activated when the alarm is on,
- Change PIN – change the PIN code used to enter the settings,
- Time and date – set the time and date
- Transport mode – activate/deactivate the transport mode,
- Info – information about the BS-09 unit and the manufacturer,
- Exit – exit the settings menu.

**IMPORTANT!** Do not forget the PIN code for entering the settings mode of the BS-09 unit. In case of its loss, you need to contact the manufacturer for recovery.

To move to the desired setting item, press MODE button to join the corresponding item with the cursor and press INPUT.

To change the settings in the menu items “Sound”, “Language”, “Transport mode”, make the desired item active (point to it with ) by pressing the MODE button and use INPUT button to change the parameter. Depending on the menu item, the value will change, for example, **ON**, **OFF** for “Sound” item.

To change the settings in “Threshold 1”, “Threshold 2”, “Internet”, “Relay settings”, “Change PIN”, “Time and date”, “Info” items, make the desired item active (point to it with ) by pressing MODE button, then use INPUT button to confirm the selection and move to the selected item. Each of the settings menu items contains  (save) and  (back) icons, which are responsible for saving the settings and/or returning to the previous menu without saving the settings, respectively. The items “Internet”, “Relay settings”, “Time and date” will have their own set of parameters, which is described below.

To select the desired icon, press MODE button until the icon is highlighted with a green line (for example, ) , then press INPUT button to confirm the action.

To exit the “Info” item, press INPUT button.

#### 2.4.4.1 Threshold 1

In the “Threshold 1” item (Figure 10), pressing MODE button moves the cursor to the right along the fields of the warning threshold input, confirmation or cancellation.

Pressing INPUT button will increment the digit in the corresponding input field or confirm or cancel the action.

The warning threshold level THD1 is programmed in the format XXX.XX in xSv/h (where x is the prefix of the unit of measurement). The BS-09 unit signals the exceeding of this threshold level by a light (yellow) or light & sound signal.

If during exceeding THD1 the level of photon-ionizing radiation DER decreases by 20 % from the set one, the BS-09 unit switches off the alarm.



Figure 10 – Threshold 1

#### 2.4.4.2 Threshold 2

In the “Threshold 2” item (Figure 11), pressing MODE button moves the cursor to the right along the fields of the safety threshold input, confirmation or cancellation.

Pressing INPUT button will increment the digit in the corresponding input field or confirm or cancel the action.

The safety threshold level THD2 is programmed in the format XXX.XX in xSv/h (where x is the prefix of the unit of measurement). The BS-09 unit signals the exceeding of this threshold level by a light (red) or light & sound signal.

If during exceeding THD2 the level of photon-ionizing radiation DER decreases by 20 % from the set level, the BS-09 unit proceeds to the warning alarm. In case of such transition, if the sound alarm is on, it will continue to be generated.



Figure 11 – Threshold 2

### 2.4.4.3 Internet

In the “Internet” item (Figures 12, 13) there is a submenu consisting of “Mode”, “Exit” and, depending on the selected mode: “IP and Port”, “Netmask address”, “Gateway address” for TCP/IP or “Port” for DHCP.

#### 2.4.4.3.1 Mode

Use the “Mode” item to select how the network parameters will be set.

In case of “TCP/IP”, the IP address, port, subnet mask, and gateway address are set manually.

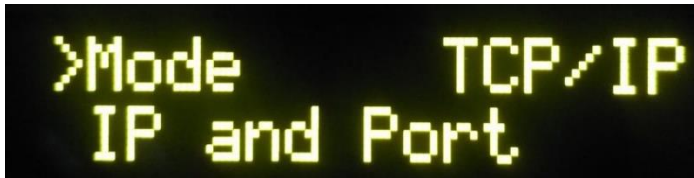

Figure 12 –“TCP/IP” mode

In case of “DHCP”, the IP address, subnet mask, and gateway address are specified by the server.



Figure 13 –“DHCP” mode

When you press the MODE button, you proceed to the next item.

When you press the INPUT button you can change the mode between “TCP/IP” and “DHCP”.

#### 2.4.4.3.2 IP and Port

Use “IP and Port” to set a static IP address and port. When you press the MODE button, you move to the right along the input fields, confirmation or cancellation.

Pressing the INPUT button will increment the digit in the corresponding input field or confirm or cancel the action.



Figure 14 – IP address and port

#### 2.4.4.3.3 Netmask address

Use the “Netmask address” item to set the netmask address. When you press the MODE button, you move to the right along the input fields, confirmation or cancellation.

By pressing the INPUT button you will increment the digit in the corresponding of input field or confirm or cancel the action.



Figure 15 – Netmask address

#### 2.4.4.3.4 Gateway address

Use the “Gateway address” to set the gateway address. When you press the MODE button, you move to the right along the input fields, confirmation or cancellation.

By pressing the INPUT button you will increment the digit in the corresponding input field or confirm or cancel the action.

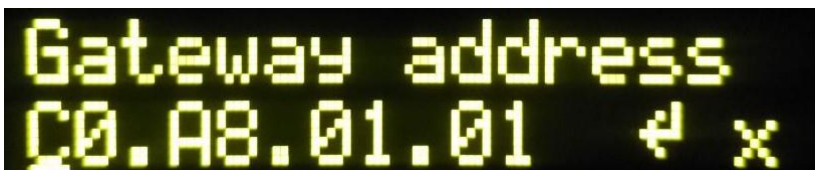

Figure 16 – Gateway address

#### 2.4.4.3.5 Port for DHCP

Use the “Port” item to set the port. When you press the MODE button, you move to the right along the input fields, confirmation or cancellation.

By pressing the INPUT button you will increment the digit in the corresponding input field or confirm or cancel the action.



Figure 17 – Port

#### 2.5 Relay settings

The “Relay settings” item (Figure 18) has its own submenu, which consists of items “Initial state”, “Turn on time”, “Turn off time”, “Exit”.

When you press the MODE button you move down the menu items.

By pressing the INPUT button you will change the parameter or go to the appropriate item. In the “Initial state” item, the values (**ON**, **OFF**) change.



Figure 18 – Relay settings

##### 2.5.1 Turn on time

The “Turn on time” item is used to set in how many milliseconds after the alarm is triggered, the relay status will change (hereinafter referred to as switching on the relay). When you press the MODE button, you move to the right along the input fields, confirmation or cancellation.

By pressing the INPUT button you will increment the digit in the corresponding input field or confirm or cancel the action.



Figure 19 – Turn on time

### 2.5.2 Turn off time

Use the “Turn off time” item to set in how many milliseconds the relay will return to its original state (hereinafter – relay shutdown). If the time before the relay is switched off is set to 0 ms, dashes are displayed instead of digits (Figure 21). If the time before switching off is zero, the relay switches off only when the alarm is switched off.

When you press the MODE button, you move to the right along the input fields, confirmation or cancellation.

By pressing the INPUT button you will increment the digit in the corresponding input field or confirm or cancel the action.

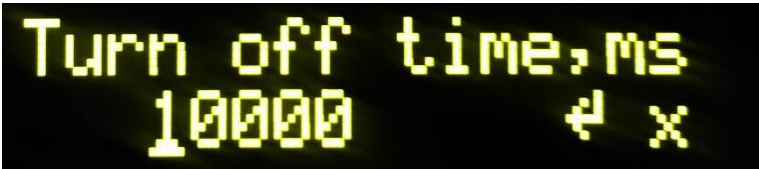

Figure 20 – Turn off time



Figure 21 – Turn off time of the relay set to 0 ms

### 2.6 Changing PIN

In the “Change PIN” item (Figure 22), when you press the MODE button, you can move along the fields of PIN code input, confirmation or cancellation.

By pressing the INPUT button you will increment the digit in the corresponding input field or confirm or cancel the action



Figure 22 – PIN change



## 2.7 Time and date

In the “Time and date” item (Figure 23) there is a submenu, which consists of items “Time setting”, “Date setting”, “Log interval”, “Exit”.

By pressing the MODE button you move down the submenu items.

By pressing the INPUT button you proceed to the corresponding item.



Figure 23 – Time and date

### 2.7.1 Time setting

Use the “Time setting” to set the current time.

By pressing the MODE button you move to the right along the input fields, confirmation or cancellation.

By pressing the INPUT button will increment the digit in the corresponding input field or confirm or cancel the action.



Figure 24 – Time settings

### 2.7.2 Date setting

Use the “Date setting” to set the current date.

By pressing the MODE button you move to the right along the input fields, confirmation or cancellation.

By pressing the INPUT button will increment the digit in the corresponding input field or confirm or cancel the action.



Figure 25– Date setting

### 2.7.3 Logging interval

Use the “Log interval” item to set the interval between logging (memorizing) information during backup power supply.

By pressing the MODE button you move to the right along the input fields, confirmation or cancellation.

By pressing the INPUT button will increment the digit in the corresponding input field or confirm or cancel the action.

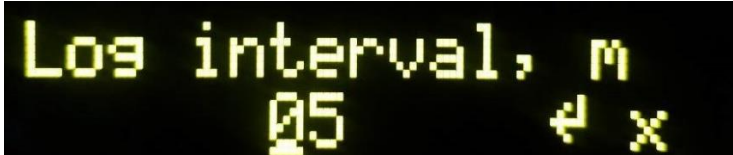

Figure 26– Logging interval

### 2.8 Info

“Info” item contains contact details of the manufacturer.

### 2.9 Charge control and backup power supply

When switched on, the BS-09 unit checks the current battery level and, if the charge level is below 95%, it switches on charging. In the event that the external power supply is unavailable, the battery power is automatically turned on, which allows you to ensure the operation of the BS-09 unit for up to 24 hours.

During the first 6 seconds when there is no external power supply of the BS-09 unit, the DER values and the “DC Reserve” inscription are alternately displayed.



Figure 27– DER value during backup power supply



Figure 28 – “DC Reserve” inscription

In the future, the BS-09 unit will display the value for 2 seconds every 30 seconds. If the set threshold level is exceeded, the BS-09 unit turns on the alarm until the user confirms that this threshold level has been exceeded using one of the buttons on the device. When the alarm is active, there is a continuous indication of DER values on the display, respective sound and light alarms, as well as data logging.

**IMPORTANT!** If the BS-09 unit is in backup power mode, it does not respond to any user queries. If the alarm has been activated, press any button to deactivate it.

#### 2.10 Exchange of information with external devices

The BS-09 unit provides information exchange via Ethernet and RS-485 interfaces with data communication protocols with a 4-bit address field (v1.2), as well as a version with an 8-bit address field (v1.3) of the Ecotest protocol, “ModBusRTU” and “ModBusTCP” protocols, as well as “HTTP” protocols (Annex H).

#### 2.11 Exchange of information via Ethernet interface

The exchange of information via the Ethernet interface supports the following protocols (Annex H):

- “Ecotest” v1.2
- “Ecotest” v1.3
- “ModBusTCP”
- “HTTP”

#### 2.12 Information exchange via RS-485 interface

The exchange of information via the RS-485 interface supports the following protocols (Annex H):

- “Ecotest” v1.2
- “Ecotest” v1.3
- “ModBusRTU”

**IMPORTANT!!!** External devices contact the BS-09 unit at its own address.

#### 2.13 Information exchange with the detecting unit

The exchange of information with the detecting unit via the RS-485 interface takes place using the “Ecotest” protocol v1.2 (Annex H).

**IMPORTANT!!!** The address of the detecting unit must be 1 (one), otherwise the detecting unit will not respond to the queries from the BS-09 unit.

## 2.14 List of possible troubles and troubleshooting

2.14.1 The list of possible troubles and troubleshooting are specified in Table 4. Troubles during use are recorded in the Table of Annex A of the OM.

Table 4 – List of possible troubles and troubleshooting

Trouble, external manifestations and additional signs	Probable cause	Troubleshooting
Firmware check is negative	Software failure	Send for repair to the manufacturer
Four LEDs are simultaneously switched on	Incorrect start of the BS-09 unit	Disconnect the power supply and wait 15 seconds before turning it on again
Battery of BS-09 unit is not charging	Power adapter has failed	Replace the power adapter
No Ethernet connection	Incorrect settings	Check the Ethernet parameters. Reboot the BS-09 unit
No RS-485 connection	Incorrect parameters	Check the baudrate settings and the BS-09 address. (Annex G) Reboot the BS-09 unit
Flashing of the light and sound alarm with red color and “Err 1” error message	Disconnection with the detecting unit	Check the reliability of the connection
Self-test results of the connected detecting unit are negative	Detecting unit failure	Replacement of the detecting unit

2.14.2 In case of failure to eliminate the troubles presented in Table 4, or at detection of more complicated troubles, the BS-09 unit should be sent for repair to the manufacturer

### 3 TECHNICAL MAINTENANCE

#### 3.1 Technical maintenance of the BS-09 unit

##### 3.1.1 General instructions

The list of operations performed during technical maintenance (hereinafter called TM) of the BS-09 unit, the order and peculiarities of operational phases are presented in Table 5.

Table 5 – List of operations during technical maintenance

Operations	TM type			OM item No.
	during		During long-term storage	
	Everyday use	Periodical use (annually)		
External examination	+	+	+	3.1.3.1
Delivery kit completeness check	-	+	+	3.1.3.2
Operability check	+	+	+	3.1.3.3.1
Battery status control				
Control of communication interfaces	+	+	+	3.1.3.4
	-	+	+	3.1.3.3.2 – 3.1.3.3.3
<p><b>Note.</b> “+” means the operation is applicable for this type of TM; “-” means the operation is not applicable.</p>				

##### 3.1.2 Safety measures

TM safety measures fully comply with safety measures stated in item 2.3.1 of the present OM.

##### 3.1.3 Maintenance procedure of the BS-09 unit

###### 3.1.3.1 External examination

External examination of the BS-09 unit should be performed in the following order:

- a) check the technical condition of surface of the BS-09 unit, inspect for integrity of seals, absence of scratches, traces of corrosion, surface damage;
- b) check the condition of connections of the BS-09 unit.

###### 3.1.3.2 Delivery kit completeness check

Check if the delivery kit of the BS-09 unit is complete according to Table 2.

### 3.1.3.3 Operability check of the BS-09 unit

3.1.3.3.1 Operability check of the BS-09 unit and its order is performed according to item 2 of the present OM.

#### 3.1.3.3.2 Operability check of the communication interfaces

Technological software (Annex F) is used to test the “Ecotest” v1.2 and “ModBus” protocols (Annex H) via the Ethernet and RS-485 interfaces. The HTTP protocol is checked using the device's built-in web interface (Annex G). What is more, when using third-party programs that have the ability to transmit information via the protocols from Annex H.

#### 3.1.3.3.3 Operability check of communication with the detecting unit.

Switch on the BS-09 unit according to 2.6.1, and use the appropriate cable to connect the detecting unit to the BS-09 unit.

### 3.1.3.4 Battery status control.

#### 3.1.3.4.1 Daily battery status control.

After switching on the BS-09 unit, check the battery charge level according to the indicator on the display.

#### 3.1.3.4.2 Checking the battery before long-term storage.

Before long-term storage of the BS-09 unit, perform the following operations:

- turn on the BS-09 unit;
- check the battery status according to the indicator on the display, if the battery is discharged – fully charge it.

The battery must be replaced every 5 years. If it is not possible to fully charge the battery during the five-year period, you need to replace the battery early.

#### 4 CERTIFICATE OF ACCEPTANCE

The BS-09 gamma radiation alarm unit of BICT.468382.057-02 type with \_\_\_\_\_ serial number, MAC address \_\_\_\_\_ , was manufactured and accepted in accordance with the mandatory requirements of state standards, current technical documentation and is accepted for use.

QCD representative

Seal here

\_\_\_\_\_  
personal signature  
\_\_\_\_\_  
year, month, date

\_\_\_\_\_  
print full name

#### 5 PACKING CERTIFICATE

The BS-09 gamma radiation alarm unit of BICT.468382.057-02 type with \_\_\_\_\_ serial number is packed by the Private Enterprise “SPPE “Sparing-Vist Center” in accordance with the requirements specified in valid technical documentation.

Seal her

\_\_\_\_\_  
position

\_\_\_\_\_  
personal signature

\_\_\_\_\_  
print full name

\_\_\_\_\_  
year, month, date

## **6 WARRANTY**

6.1 The manufacturer guarantees the conformity of the BS-09 unit with the OM requirements if the customer observes the guidelines for its use, shipping and storage presented in the operating manual BICT.468382.057-02 HE. The warranty period of the BS-09 unit use shall terminate and be of no further effect in 24 months after the date of putting it into operation or after the warranty period of storage terminates. The warranty period of storage is 6 months after its manufacture date.

6.2 The warranty period is extended for the period during which the warranty repair is performed.

6.3 In case of violation of the conditions of use, transportation and storage, in the presence of mechanical damage, as well as in case of violation of seals, repairs are performed at the consumer's expense.

6.4 After the expiration of the warranty period of use of the BS-09 unit, repairs are performed under separate agreements.

6.5 Warranty repairs are carried out only by the manufacturer. Post-warranty repairs are carried out by the manufacturer or the company designated by it.



## 7 REPAIR

7.1 In case of failure or troubles during the warranty period of the BS-09 unit use, the consumer must draw up an act on the need for repair and send the BS-09 unit to the manufacturer:

*PE "SPPE "Sparing-Vist Center"*

*33 Volodymyra Velykoho Str., Lviv, 79026*

*Tel.: (+380 32) 242-15-15; Fax: (+380 32) 242-20-15;*

*E-mail: sales@ecotest.ua.*

7.2 All claims are registered in Table 6.

Table 6

Date of failure	Claim summary	Action taken	Note

## 8 SHIPPING AND STORAGE

8.1 The BS-09 units in the package can be transported by rail and road transport of closed type, as well as by air in pressurized compartments. Transportation can be carried out by one mode of transport or several types in any order, and the number of reloadings should not exceed four.

8.2 The BS-09 unit in the package during transportation is resistant to the influence of air temperature from minus 20 °C to plus 55 °C, relative humidity (95 ± 3)% at a temperature of 35 °C and atmospheric pressure from 84 kPa to 106.7 kPa.

8.3 The BS-09 unit in the package can withstand transportation by rail and air (in airtight compartments) transport without distance restrictions.

8.4 The BS-09 unit in the package can withstand transportation by road:

- on roads with asphalt and concrete pavement at a distance of up to 1000 km;
- on cobblestones and dirt roads at a distance of up to 250 km at speeds up to 40 km/h.

8.5 The BS-09 unit in the package is resistant to shock loads, the values of which are shown in Table 7.

Table 7 – Resistance of the BS-09 unit to shock loads

Shock acceleration peak value, m/s <sup>2</sup> (g)	Duration of shock acceleration, ms	Number of shocks
750 (75)	2 - 6	200
150 (15)	5 - 20	2000
100 (10)	5 - 20	8800

8.6 The BS-09 unit in the package can be stored in heated and ventilated warehouses, storages with air conditioning at air temperature from 5 °C to 40 °C, relative humidity not exceeding 80% at 25 °C temperature, atmospheric pressure from 84 kPa to 106.7 kPa. Shelf life before commissioning is up to 6 months, or up to one year if the battery is recharged in 6 months after storage begins.

## **9 DISPOSAL**

Disposal of the BS-09 unit should be carried out in accordance with DSTU 4462.3.01:2006, DSTU 4462.3.02:2006 standards, the Laws of Ukraine “On Environmental Protection” and “On Waste”.

Note. In case of contamination of the BS-09 unit with liquid or bulk substances containing radionuclides and impossibility of its decontamination, the BS-09 unit shall be disposed of as solid radioactive waste.

Disposal of the BS-09 unit is not dangerous for service personnel, and is environmentally friendly.

## ANNEX A

### TROUBLE RECORD DURING USE

Date and time of failure. Operating mode	Type (manifestation) of trouble	Cause of trouble, number of operation hours of the failed element	Action taken and claim note	Position, name and signature of the person responsible for solving the problem	Note

## ANNEX B

### REPAIR OF BS-09 UNIT

Position, name and signature of the responsible person	who performed repair	who accepted after repair	
Name of repair works			
Type of repair			
Number of operation hours before repair			
Name of the repair organization			
Date	of arriving for repair	of repair completion	
	of arriving for repair	of repair completion	
Reason for repair			
Name and type of the component part of BS-09 unit			

## ANNEX C

### STORAGE

Date		Storage conditions	Position, name and signature of the responsible person
of placing in storage	of removing from storage		

**ANNEX D**

**PUTTING IN PROLOGED STORAGE AND REMOVAL FROM STORAGE DURING USE OF BS-09 UNIT**

Date of putting in prolonged storage	Storage method	Date of removal from prolonged storage	Name or symbol of the company in charge of putting or removing from prolonged storage of BS-09 unit	Date, position and signature of the responsible person

**ANNEX E**

**VERIFICATION AND INSPECTION RESULTS**

Date	Verification or inspection type	Verification or inspection result	Position, name and signature of the person responsible for inspection	Note



## ANNEX F

### INSTRUCTIONS FOR USING THE “TEO SYSTEM” TECHNOLOGICAL PROGRAM

Technological software “Teo system” is designed to test the operation of the BS-09 unit after manufacture, repair, with various communication protocols outside the object of application.

Run the “Teo system” technological program (hereinafter – the technological program).

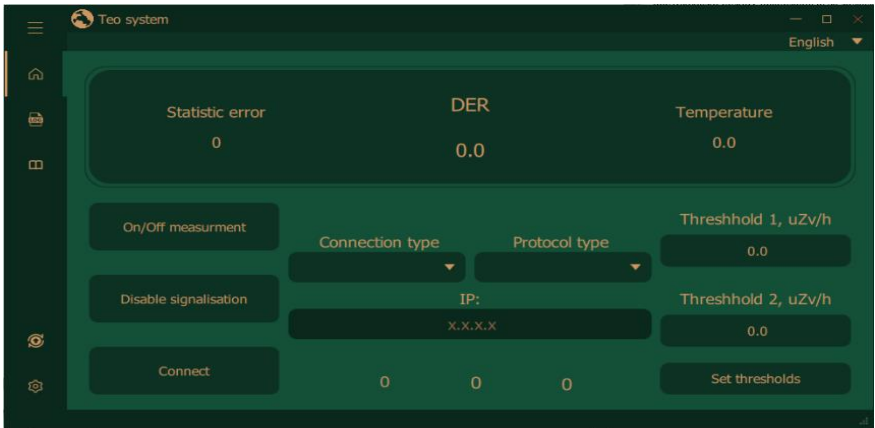

Figure F.1 – View of the main window of the technological program

After launching the technological program, its main window opens.

Initial settings:

Use the “Connection type” list to select the interface type (Figure F.2).

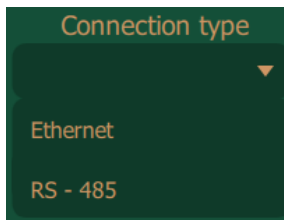

Figure F.2 – List of supported interface types

Use the “Protocol Type” list (Figure F.3) to select the protocol type.

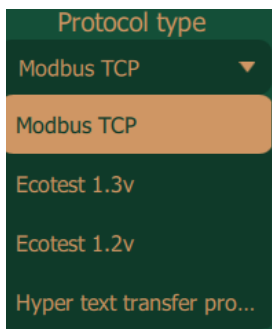

Figure F.3 – List of supported protocol types

Depending on the type of connection, you need to enter the IP address or select the COM port depending on the interface type - communication with the BS-09 unit will take place under the “Ecotest” or “ModBus<sup>3</sup>” protocol.

**IMPORTANT!!!** When using the RS-485 interface, you must specify the correct address, otherwise the BS-09 unit will not respond to the user queries.

After making the settings described above, you need to click “Connect”. After clicking, the connection to the BS-09 unit will be made, the thresholds (Figure F.4) and the serial number of the detecting unit will be read.



Figure F.4 – Reading thresholds when connecting

---

<sup>3</sup> The name “ModBus” is used as a general name for the specific protocols “ModBusRTU” and “ModBusTCP”.

To start reading the measurements from the detecting unit, click the button shown in Figure F.5.



Figure F.5 – Start reading measurements

To stop reading measurements from the detecting unit, click the button shown in Figure F.6:

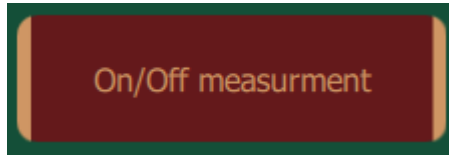

Figure F.6 – Stop reading measurements

After the start of measurements readings from the detecting unit (Figure F.7), DER, statistical error, temperature and self-test results of the detecting unit will be displayed in the corresponding windows.

Statistic error	DER	Temperature
53	0.13	25.0

Figure F.7 – Reading measurements from the detecting unit

To change the thresholds, you must first make sure that the reading of the measurements is suspended (Figure F.6). Then, by writing the values in the appropriate fields (Figure F.4) (we must assume that the threshold 1 is < than threshold 2), click “Set thresholds” (Figure F.4).

## ANNEX G

### INSTRUCTIONS FOR USING THE WEB INTERFACE OF THE BS-09 UNIT

For remote configuration, the web interface of the BS-09 unit is available, which can be accessed at the IP address that is recorded in the settings of the BS-09 unit (by default it is 192.168.1.220).

Use the Ethernet cable to connect to the BS-09 unit. After that turn on the BS-09 unit in accordance with paragraph 2.4.1 of this OM.

You need to open the Ethernet network adapter settings on the user's PC. In these settings you need to open the properties of the Internet Protocol version 4 (TCP/IPv4). Select "Use this IP address" (Figure G.1 – Properties of the Internet Protocol version 4 (TCP/IPv4)) and set the parameters in accordance with the requirements of the TCP/IP protocol.

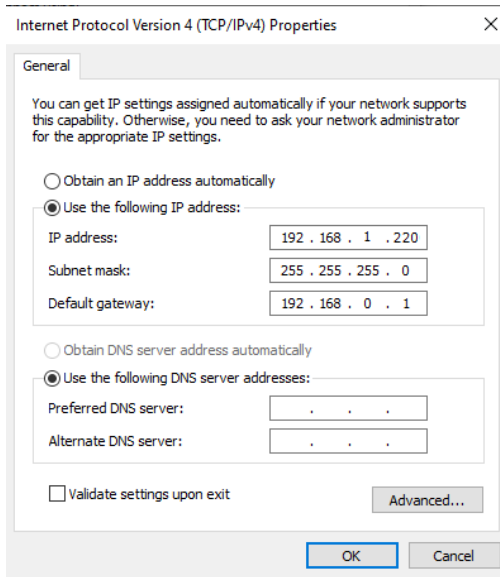

Figure G.1 - Properties of the Internet Protocol version 4 (TCP/IPv4)

Write the appropriate IP address in the browser in the address bar (by default it is 192.168.1.220) (Figure G.2) and confirm the action.

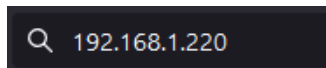

Figure G.2 – Address bar

After that, the web interface page of the BS-09 unit will be displayed.



Figure G.3 – Html page

**Read data:** To read data from the BS-09 unit, click the “Read data” button. Then the button will change color (Figure G.4). Data is read every second.

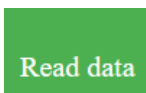

Figure G.4 – Active data read button

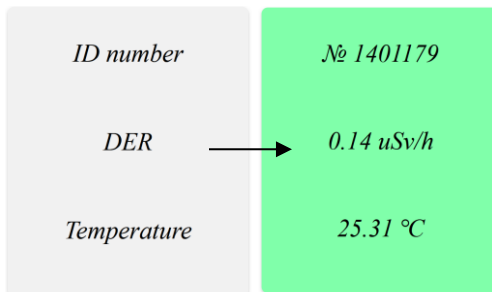

Figure G.5 – Read data

If data is not reliable or there is no connection to the detecting unit, the dose rate will be grayed out. If there is a loss of communication with the detecting unit, there will be a dash in place of the read data.

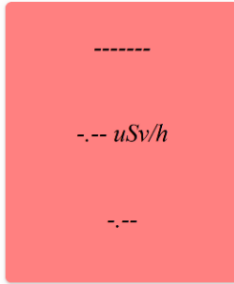

Figure G.6 – Read data (in case of loss of communication with the detecting unit)

**Save data:** To save the read data in a JSON file, click the “Save data” button. Each value obtained when reading data is stored (reading take place once a second).

**Read settings:** Reads the list of settings from the BS-09 unit. For this purpose you need to enter the PIN code, which is set in the BS-09 unit (default value is 0000) (Figure G.7)

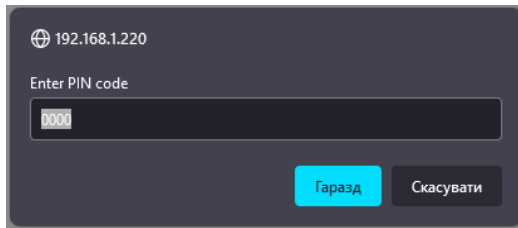

Figure G.7 – Window for entering PIN code

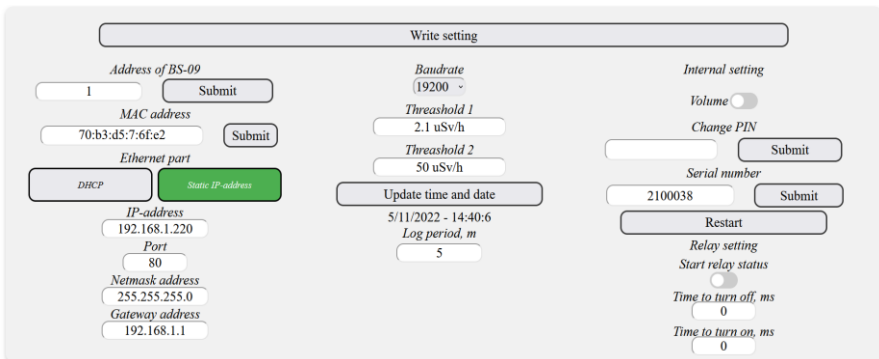

Figure G.8 – Window of read settings

**Address of BS-09:** This item allows you to change the address, to which the BS-09 unit will respond when using the RS-485 interface.



Figure G.9 – Address of BS-09 unit

**MAC address:** This item allows you to change the MAC address..

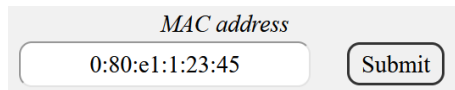

Figure G.10 – MAC address of BS-09 unit

**Ethernet configuration block:** This item allows you to change the Ethernet connection settings, namely to select the IP address parameters settings (set it manually or automatically).

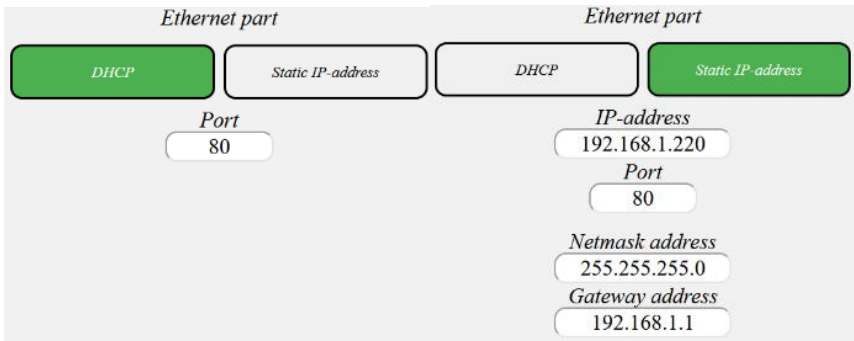

Figure G.11 – Ethernet interface settings

**Baudrate:** This item allows you to change the baudrate of the RS-485 output connection.

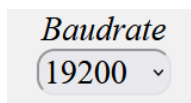

Figure G.12 – Baudrate of RS-485 output connection

**RTC data:** This item allows you to set the current date and time.

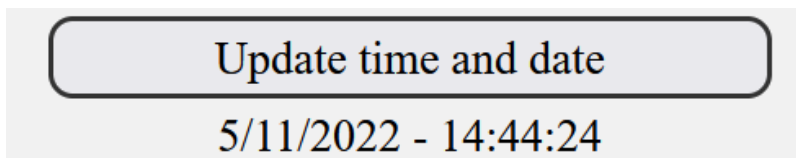

Figure G.13 – Current date and time and the button that updates them

**Log period:** This item allows you to set the logging period when there is the backup power.

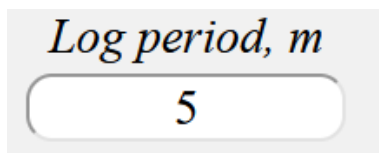

Figure G.14 – Logging period

**Internal settings block:** The block of the BS-09 unit settings allows you to enable/disable the alarm sound (“Sound” switch), change the PIN code (input field and “Confirm” button), change the serial number (input field and “Confirm” button), reboot the BS-09 unit (“Reboot” button).

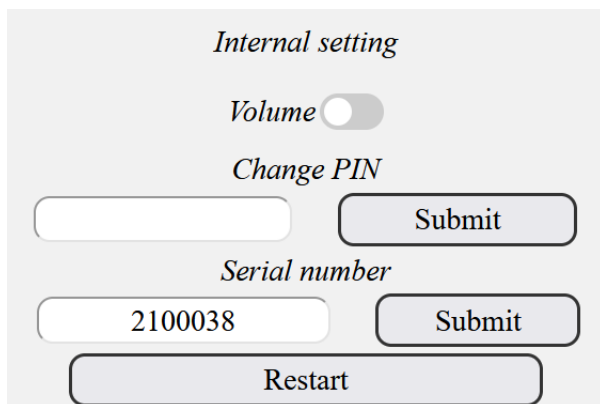

Figure G.15 – Internal settings block



**Relay setting:** Intelligent relay settings block. Initial status relay switch (Start relay status), time to relay turn off (Time to turn off), time to relay to turn on (Time to turn on).

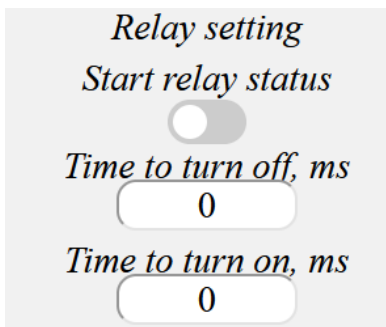

Figure G.16 – Relay setting block

**Write settings:** Write settings to the BS-09 unit. All settings for which there is no custom button (Ethernet settings, Baudrate, thresholds, logging period, serial number, relay settings, sound on/off), are set using the “Write settings” button.

## ANNEX H

### COMMUNICATIONS PROTOCOL OF THE DATA DISPLAY SYSTEM AND BS-09 UNIT

H.1 Data frames exchange between the BS-09 unit and the data display system is done via RS-485 interface in a half-duplex mode and Ethernet.

Exchange parameters via RS-485 interface:

- rate: 19,200 bps;
- data word length: 8 bit;
- parity bit: none;
- stop bit: 1.

Time interval between the bytes in one frame should not exceed 1 ms. Time interval between the frames should not be less than 5 ms.

H.2 After the supply voltage from the data display system is applied to the BS-09 unit, the latter starts automatic display of gamma radiation DER not later than in 30 s and processing of data frames from the data display system.

H.3 The BS-09 unit supports data communications protocol version with both 4-digit address field (v1.2), and 8-digit address field (v1.3) of “Ecotest” protocol, as well as “ModBusRTU” and “ModBusTCP” protocols. Hyper Text Transfer Protocol (HTTP) is also supported.

H.3.1 Communications protocol with the 4-digit address field (v1.2) via RS-485 interface.

To obtain the measured value of DER from the detecting unit, the data display system should transmit the “DER query” frame to the detecting unit. The BS-09 unit will respond in 5 ms to 15 ms with the “Current DER” frame, where current DER, maximum Statistic error of its measurement, and self-test results of the detecting unit will be displayed.

To obtain the measured value of temperature from the detecting unit (with embedded temperature detector), the data display system should transmit the “Temperature query” frame to the detecting unit. The BS-09 unit will respond in 5 ms to 15 ms with the “Current temperature” frame, where current temperature and status of the temperature detector will be provided.

To obtain the serial number of the detecting unit, the data display system should transmit the “Serial # query” frame to the detecting unit. The BS-09 unit will respond in 5 ms to 15 ms with the “Serial #” frame with the displayed serial number.

“DER query” frame format – the data display system to the BS-09 unit:

D7	D6	D5	D4	D3	D2	D1	D0	
0	1	0	1	0	1	0	1	Byte 55h – start-of-frame character
1	0	1	0	1	0	1	0	Byte AAh
0	0	0	0	A3	A2	A1	A0	D7...D4 - “DER query” frame code D3...D0 –BS-09 unit address*

\* - 0Fh address – broadcast address. All detecting units respond to the query with this address.

“Current DER” frame format – the BS-09 unit to the data display system:

D7	D6	D5	D4	D3	D2	D1	D0	
0	1	0	1	0	1	0	1	Byte 55h – start-of-frame character
1	0	1	0	1	0	1	0	Byte AAh
0	0	0	1	A3	A2	A1	A0	D7...D4 - “Current DER” frame code D3...D0 - BS-09 unit address
DER0 (low byte)								DER, fixed point number, Least significant bit (LSB) = 0.01 $\mu$ Sv/h
DER1								
DER2								
DER3 (high byte)								
Byte								Statistic error of measurement
D7	0	0	0	0	D2	D1	D0	D0, D1 - self-test results of the detecting unit D0=1 - failure of the high sensitivity detector D1=1 - failure of the low sensitivity detector Reliable measurement result character D2=0 - result is true D2=1 – result is false* D7=0 – LSB DER = 0,01 $\mu$ Sv/h D7=1 – LSB DER = 0,1 $\mu$ Sv/h
control								arithmetical checksum with a carry

- measurement result is accepted as false if the Statistic error of measurement exceeds maximum permissible error of measurement.

“Temperature query” frame format – the data display system to the BS-09 unit

D7	D6	D5	D4	D3	D2	D1	D0	
0	1	0	1	0	1	0	1	Byte 55h – start-of-frame character
1	0	1	0	1	0	1	0	Byte AAh
1	0	0	0	A3	A2	A1	A0	D7...D4 - “Temperature query” frame code D3...D0 - BS-09 unit address*

\* - 0Fh address – broadcast address. All detecting units respond to the query with this address.

“Current temperature” frame format – the detecting unit to the data display system

D7	D6	D5	D4	D3	D2	D1	D0	
0	1	0	1	0	1	0	1	Byte 55h – start-of-frame character
1	0	1	0	1	0	1	0	Byte AAh
1	0	0	0	A3	A2	A1	A0	D7...D4 –“Current temperature” frame code D3...D0 - BS-09 unit address
$2^3$	$2^2$	$2^1$	$2^0$	$2^{-1}$	$2^{-2}$	$2^{-3}$	$2^{-4}$	Temperature, binary number
D7	X	X	X	S	$2^6$	$2^5$	$2^4$	S=0-above-zero temperature S=1-below-zero temperature D7=0-normal operation of thermal detector D7=1-failure of thermal detector
control								arithmetical checksum with a carry

“Factory # query” frame format – the data display system to the BS-09 unit

D7	D6	D5	D4	D3	D2	D1	D0	
0	1	0	1	0	1	0	1	Byte 55h – start-of-frame character
1	0	1	0	1	0	1	0	Byte AAh
0	1	0	1	A3	A2	A1	A0	D7...D4 - “Factory # query” frame code D3...D0 - BS-09 unit address*

\* - 0Fh address – broadcast address. All detecting units respond to the query with this address.

“Factory #” frame format – the BS-09 unit to the data display system

D7	D6	D5	D4	D3	D2	D1	D0	
0	1	0	1	0	1	0	1	Byte 55h – start-of-frame character
1	0	1	0	1	0	1	0	Byte AAh
0	1	0	1	A3	A2	A1	A0	D7...D4 - “Factory #” frame code D3...D0 - BS-09 unit address
Factory No._0 (low byte)								Factory No. of the detecting unit
Factory No._1								
Factory No._2								
Factory No._3 (high byte)								
control								arithmetical checksum with a carry

“Serial # query” frame format – the data display system to the BS-09 unit

D7	D6	D5	D4	D3	D2	D1	D0	
0	1	0	1	0	1	0	1	Byte 55h – start-of-frame character
1	0	1	0	1	0	1	0	Byte AAh
1	1	0	1	A3	A2	A1	A0	D7...D4 - “Serial # query” frame code D3...D0 - BS-09 unit address*

\* - 0Fh address – broadcast address. All detecting units respond to the query with this address.

“Serial #” frame format – the BS-09 unit to the data display system

D7	D6	D5	D4	D3	D2	D1	D0	
0	1	0	1	0	1	0	1	Byte 55h – start-of-frame character
1	0	1	0	1	0	1	0	Byte AAh
1	1	0	1	A3	A2	A1	A0	D7...D4 - “Serial #” frame code D3...D0 - BS-09 unit address
Serial No._0 (low byte)								Serial No. of the detecting unit
Serial No._1								
Serial No._2								
Serial No._3 (high byte)								
control								arithmetical checksum with a carry

“Threshold query” frame format – the data display system to the BS-09 unit:

D7	D6	D5	D4	D3	D2	D1	D0	
0	1	0	1	0	1	0	1	Byte 55h – start-of-frame character
1	0	1	0	1	0	1	0	Byte AAh
1	1	0	0	A3	A2	A1	A0	D7...D4 - “Threshold query” frame code D3...D0 - BS-09 unit address*

\* - 0Fh address – broadcast address. All detecting units respond to the query with this address.

“Threshold query” frame format – the BS-09 unit to the data display system:

D7	D6	D5	D4	D3	D2	D1	D0	
0	1	0	1	0	1	0	1	Byte 55h – start-of-frame character
1	0	1	0	1	0	1	0	Byte AAh
1	1	0	0	A3	A2	A1	A0	D7...D4 - “Threshold query” frame code D3...D0 - BS-09 unit address*
Threshold0								Threshold_1 (DWORD)
Threshold1								
Threshold2								
Threshold3								
Threshold0								Threshold_2 (DWORD)
Threshold1								
Threshold2								
Threshold3								
control								arithmetical checksum with a carry

“Threshold setting” frame format – the data display system to the BS-09 unit:

D7	D6	D5	D4	D3	D2	D1	D0	
0	1	0	1	0	1	0	1	Byte 55h – start-of-frame character
1	0	1	0	1	0	1	0	Byte AAh
0	1	1	0	A3	A2	A1	A0	D7...D4 - “Threshold setting” frame code D3...D0 - BS-09 unit address*
Threshold0								Threshold_1 (DWORD)
Threshold1								
Threshold2								
Threshold3								
Threshold0								Threshold_2 (DWORD)
Threshold1								
Threshold2								
Threshold3								
control								arithmetical checksum with a carry

“Threshold setting” frame format – the BS-09 unit to the data display system:

D7	D6	D5	D4	D3	D2	D1	D0	
0	1	0	1	0	1	0	1	Byte 55h – start-of-frame character
1	0	1	0	1	0	1	0	Byte AAh
0	1	1	0	A3	A2	A1	A0	D7...D4 - “Threshold setting” frame code D3...D0 - BS-09 unit address*
1/0	0	0	0	0	0	1	1	D7 = 0 – normal operation D7 = 1 - error
control								arithmetical checksum with a carry



“Alarm conformation” frame format – the data display system to the BS-09 unit:

D7	D6	D5	D4	D3	D2	D1	D0	
0	1	0	1	0	1	0	1	Byte 55h – start-of-frame character
1	0	1	0	1	0	1	0	Byte AAh
1	0	0	1	A3	A2	A1	A0	D7...D4 - “Alarm conformation” frame code D3...D0 - BS-09 unit address*

\* - 0Fh address – broadcast address. All detecting units respond to the query with this address.

“Alarm conformation” frame format – the BS-09 unit to the data display system:

D7	D6	D5	D4	D3	D2	D1	D0	
0	1	0	1	0	1	0	1	Byte 55h – start-of-frame character
1	0	1	0	1	0	1	0	Byte AAh
1	0	0	1	A3	A2	A1	A0	D7...D4 - “Alarm conformation” frame code D3...D0 - BS-09 unit address*
1/0	0	0	0	0	0	1	1	D7 = 0 – normal operation D7 = 1 - error
control								arithmetical checksum with a carry

### H.3.2 Communications protocol with the 8-digit address field (v1.3).

To receive the measured value of DER from the detecting unit, the data display system should transmit the “DER1 query” frame to the detecting unit. The detecting unit will respond in 5 ms to 15 ms with the “Current DER1” frame, where current DER, maximum Statistic error of its measurement, and self-test results of the detecting unit will be displayed.

To obtain the measured value of temperature from the detecting unit (with embedded temperature detector), the data display system should transmit the “Temperature1 query” frame to the detecting unit. The detecting unit will respond in 5 ms to 15 ms with the “Current temperature1” frame, where current temperature and status of the temperature detector will be provided.

To obtain the serial number of the detecting unit and the response delay factor to broadcast query, the data display system should send the “Serial #\_1 query” frame to the detecting unit. The detecting unit will respond in 5 ms to 15 ms with the “Serial #\_1” frame with the displayed serial number and the response delay factor to the broadcast query.

To make operation with several detecting units (up to 255 units) easier that are simultaneously connected to the data display system via single RS-485 interface, the 0FFh broadcast address is provided. The use of the broadcast address is permitted only in the “DER1 query”, “Temperature1 query” and “Serial #\_1 query” frames. All detecting units respond to the query with such address (broadcast query).

When the detecting units respond to the broadcast query, each of them does it with delay T, which is calculated by the formula:

$$T = 5 \text{ mS} + t \times 8 \text{ mS}, \quad (\text{H.1})$$

if the response delay factor to the broadcast query t is within the range from 0 to 15;

or by the formula:

$$T = (5 \text{ mS} + t \times 8 \text{ mS}) + 125 \text{ mS}, \quad (\text{H.2})$$

if the response delay factor to the broadcast query t is within the range from 16 to 255.

The broadcast query also enables easy autodetection of the detecting units that connect/disconnect to/from the data display system in the process of system operation.

“DER1 query” frame format –the data display system to the detecting unit:

D7	D6	D5	D4	D3	D2	D1	D0	
0	1	0	1	0	1	0	1	Byte 55h – start-of-frame character
1	0	1	0	1	0	1	0	Byte AAh
0	1	1	1	0	0	0	0	D7...D4– protocol v1.3 character
address								D7...D0–BS-09 unit address*
0	0	0	0	0	0	0	0	D7...D0– DER1 query” frame code
control								arithmetical checksum with a carry

\* - 0Fh address – broadcast address. All detecting units respond to the query with this address.

“Current DER1” frame format –the detecting unit to the data display system:

D7	D6	D5	D4	D3	D2	D1	D0	
0	1	0	1	0	1	0	1	Byte 55h – start-of-frame character
1	0	1	0	1	0	1	0	Byte AAh
0	1	1	1	0	0	0	0	D7...D4–protocol v1.3 character
address								D7...D0–BS-09 unit address
0	0	0	0	0	0	0	1	D7...D0–“Current DER1” frame code
DER0 (low byte)								DER, fixed point number, Least significant bit = 0.01 $\mu$ Sv/h
DER1								
DER2								
DER3 (high byte)								
Byte								Statistic error of measurement
								D0,D1 - self-test results of the detecting unit D0=1 - failure of the high sensitivity detector D1=1 - failure of the low sensitivity detector Reliable measurement result character D2=0 - result is true D2=1 – result is false *
D7	0	0	0	0	D2	D1	D0	D7=0 – LSB DER = 0.01 $\mu$ Sv/h D7=1 – LSB DER = 0.1 $\mu$ Sv/h
control								arithmetical checksum with a carry

\* - measurement result is accepted as false if the Statistic error of measurement exceeds maximum permissible error of measurement.

“Temperature1 query” frame format – the data display system to the detecting unit (for the detecting units with embedded temperature detector)

D7	D6	D5	D4	D3	D2	D1	D0	
0	1	0	1	0	1	0	1	Byte 55h – start-of-frame character
1	0	1	0	1	0	1	0	Byte AAh
0	1	1	1	0	0	0	0	D7...D4–protocol v1.3 character
address								D7...D0–BS-09 unit address*
0	0	0	0	1	0	0	0	D7...D0–“Temperature1 query” frame code
control								arithmetical checksum with a carry

\* - 0Fh address – broadcast address. All detecting units respond to the query with this address.

“Current temperature1” frame format – the detecting unit to the data display system

D7	D6	D5	D4	D3	D2	D1	D0	
0	1	0	1	0	1	0	1	Byte 55h – start-of-frame character
1	0	1	0	1	0	1	0	Byte AAh
0	1	1	1	0	0	0	0	D7...D4–protocol v1.3 character
address								D7...D0–BS-09 unit address
0	0	0	0	1	0	0	0	D7...D0–“Current temperature1” frame code
$2^3$	$2^2$	$2^1$	$2^0$	$2^{-1}$	$2^{-2}$	$2^{-3}$	$2^{-4}$	Temperature, binary number
D7	X	X	X	S	$2^6$	$2^5$	$2^4$	S=0-above-zero temperature S=1-below-zero temperature D7=0-normal operation of thermal detector D7=1-failure of thermal detector
control								arithmetical checksum with a carry

“Factory #1 query” frame format – the data display system to the BS-09 unit

D7	D6	D5	D4	D3	D2	D1	D0	
0	1	0	1	0	1	0	1	Byte 55h – start-of-frame character
1	0	1	0	1	0	1	0	Byte AAh
0	1	1	1	0	0	0	0	D7...D4– protocol v1.3 character
address								D7...D0– BS-09 unit address*
0	0	0	0	0	1	0	1	D7...D0–“Factory #1 query” frame code
control								arithmetical checksum with a carry

\* - 0Fh address – broadcast address. All detecting units respond to the query with this address.

“Factory #\_1” frame format – the BS-09 unit to the data display system

D7	D6	D5	D4	D3	D2	D1	D0	
0	1	0	1	0	1	0	1	Byte 55h – start-of-frame character
1	0	1	0	1	0	1	0	Byte AAh
0	1	1	1	0	0	0	0	D7...D4– protocol v1.3 character
address								D7...D0– BS-09 unit address
0	0	0	0	0	1	0	1	D7...D0–“Factory #_1” frame code
Factory No._0 (low byte)								Factory No. of the detecting unit
Factory No._1								
Factory No._2								
Factory No._3 (high byte)								
current constant								D7...D0 – current response delay factor to broadcast query
control								arithmetical checksum with a carry

“Serial #\_1 query” frame format – the data display system to the BS-09 unit

D7	D6	D5	D4	D3	D2	D1	D0	
0	1	0	1	0	1	0	1	Byte 55h – start-of-frame character
1	0	1	0	1	0	1	0	Byte AAh
0	1	1	1	0	0	0	0	D7...D4–protocol v1.3 character
address								D7...D0–BS-09 unit address*
0	0	0	0	1	1	0	1	D7...D0–“Serial #_1 query” frame code
control								arithmetical checksum with a carry

\* - 0Fh address – broadcast address. All detecting units respond to the query with this address.

“Serial #\_1” frame format – the BS-09 unit to the data display system

D7	D6	D5	D4	D3	D2	D1	D0	
0	1	0	1	0	1	0	1	Byte 55h – start-of-frame character
1	0	1	0	1	0	1	0	Byte AAh
0	1	1	1	0	0	0	0	D7...D4–protocol v1.3 character
address								D7...D0–BS-09 unit address
0	0	0	0	0	1	0	1	D7...D0–“Serial #_1” frame code
Serial No._0 (low byte)								Serial No. of the detecting unit
Serial No._1								
Serial No._2								
Serial No._3 (high byte)								
current constant								D7...D0 – current response delay factor to broadcast query
control								arithmetical checksum with a carry

“Threshold query1” frame format – the data display system to the BS-09 unit:

D7	D6	D5	D4	D3	D2	D1	D0	
0	1	0	1	0	1	0	1	Byte 55h – start-of-frame character
1	0	1	0	1	0	1	0	Byte AAh
0	1	1	1	0	0	0	0	D7...D4–protocol v1.3 character
address								D7...D0–BS-09 unit address
0	0	0	0	1	1	0	0	D7...D0–“Threshold query1” frame code
control								arithmetical checksum with a carry

\* - 0Fh address – broadcast address. All detecting units respond to the query with this address .

“Threshold query1” frame format – the BS-09 unit to the data display system:

D7	D6	D5	D4	D3	D2	D1	D0	
0	1	0	1	0	1	0	1	Byte 55h – start-of-frame character
1	0	1	0	1	0	1	0	Byte AAh
0	1	1	1	0	0	0	0	D7...D4–protocol v1.3 character
address								D7...D0–BS-09 unit address
0	0	0	0	1	1	0	0	D7...D0–“ Threshold query1” frame code
Threshold0								Threshold_1 (DWORD)
Threshold1								
Threshold2								
Threshold3								
Threshold0								Threshold_2 (DWORD)
Threshold1								
Threshold2								
Threshold3								
control								arithmetical checksum with a carry

“Threshold setting1” frame format – the data display system to the BS-09 unit:

D7	D6	D5	D4	D3	D2	D1	D0	
0	1	0	1	0	1	0	1	Byte 55h – start-of-frame character
1	0	1	0	1	0	1	0	Byte AAh
0	1	1	1	0	0	0	0	D7...D4–protocol v1.3 character
address								D7...D0–BS-09 unit address
0	0	0	0	0	1	1	0	D7...D0–“Threshold setting1” frame code
Threshold0								Threshold_1 (DWORD)
Threshold1								
Threshold2								
Threshold3								
Threshold0								Threshold_2 (DWORD)
Threshold1								
Threshold2								
Threshold3								
control								arithmetical checksum with a carry

“Threshold setting1” frame format – the BS-09 unit to the data display system:

D7	D6	D5	D4	D3	D2	D1	D0	
0	1	0	1	0	1	0	1	Byte 55h – start-of-frame character
1	0	1	0	1	0	1	0	Byte AAh
0	1	1	1	0	0	0	0	D7...D4–protocol v1.3 character
address								D7...D0–BS-09 unit address
0	0	0	0	0	1	1	0	D7...D0–“ Threshold setting1” frame code
1/0	0	0	0	0	0	1	1	D7 = 0 – normal operation D7 = 1 - error
control								arithmetical checksum with a carry



“Alarm conformation1” frame format – the data display system to the BS-09 unit:

D7	D6	D5	D4	D3	D2	D1	D0	
0	1	0	1	0	1	0	1	Byte 55h – start-of-frame character
1	0	1	0	1	0	1	0	Byte AAh
0	1	1	1	0	0	0	0	D7...D4–protocol v1.3 character
address								D7...D0–BS-09 unit address
0	0	0	0	1	0	0	1	D7...D0–“Alarm conformation1” frame code
control								arithmetical checksum with a carry

\* - 0Fh address – broadcast address. All detecting units respond to the query with this address.

“Alarm conformation1” frame format – the BS-09 unit to the data display system:

D7	D6	D5	D4	D3	D2	D1	D0	
0	1	0	1	0	1	0	1	Byte 55h – start-of-frame character
1	0	1	0	1	0	1	0	Byte AAh
1	0	0	1	A3	A2	A1	A0	D7...D4 - “Alarm conformation1” frame code D3...D0 -BS-09 unit address*
1/0	0	0	0	0	0	1	1	D7 = 0 – normal operation D7 = 1 - error
control								arithmetical checksum with a carry

### H.3.3 “ModBusRTU” protocol via RS-485 interface

To obtain the measured value of DER from the detecting unit, the data display system must read data from two registers with numbers four and five (4 and 5). The resulting 16-bit numbers must be combined into a 32-bit one and converted to an IEEE 754 format float.

The BS-09 unit will respond in 5 ms to 15 ms according to the “ModBusRTU” protocol with data on the current DER.

D7	D6	D5	D4	D3	D2	D1	D0	Register address	
DER0 (low byte)								4	Current DER (float IEEE 754)
DER1									
DER2								5	
DER3 (high byte)									

To obtain the measured value of temperature from the BS-09 unit, the data display system must read data from two registers with numbers seven and eight (7 and 8). The resulting 16-bit numbers must be combined into a 32-bit one and converted to an IEEE 754 format float.

D7	D6	D5	D4	D3	D2	D1	D0	Register address	
Temp0 (low byte)								7	Temperature (float IEEE 754)
Temp1									
Temp2								8	
Temp 3 (high byte)									

The BS-09 unit will respond in 5 ms to 15 ms according to the “ModBusRTU” protocol with data on the current temperature.

To make operation with several detecting units (up to 255 units) easier that are simultaneously connected to the data display system via single RS-485 interface, the 0FFh broadcast address is provided. All detecting units respond to the query with such address (broadcast query).

When the detecting units respond to the broadcast query, each of them does it with delay T, which is calculated by the formula:

$$T = 5 \text{ mS} + t \times 8 \text{ mS}, \quad (\text{H.3})$$

if the response delay factor to the broadcast query t is within the range from 0 to 15;

or by the formula:

$$T = (5 \text{ mS} + t \times 8 \text{ mS}) + 125 \text{ mS}, \quad (\text{H.4})$$

if the response delay factor to the broadcast query t is within the range from 16 to 255.

The broadcast query also enables easy autodetection of the detecting units that connect/disconnect to/from the data display system in the process of system operation.

To change the address of the BS-09 unit, the data display system must record in the register 21 addresses to which it will respond. The BS-09 unit will respond with conformation in 5 ms to 15 ms according to the “ModBusRTU” protocol.

To confirm the alarm of exceeding one of the two threshold levels, you need to write 1 to the register with address 11. It is recommended for recording to use the command to write analog output (0x06);

Memory structure for “ModBus” protocol.

D7	D6	D5	D4	D3	D2	D1	D0	Register address	
Threshold0 (high byte)								0	Threshold 1 (float IEEE 754)
Threshold1									
Threshold2									
Threshold3(low byte)									
Threshold0 (high byte)								2	Threshold 2 (float IEEE 754)
Threshold1									
Threshold2									
Threshold3(low byte)								3	
DER0 (high byte)								4	DER (float IEEE 754) (only reading)
DER1									
DER2									
DER3 (low byte)								5	
Self-test results								6	Two 16-bit integers
Statistical error									
Temp0 (high byte)								7	Temperature (float IEEE 754) (only reading)
Temp1									
Temp2									
Temp3 (low byte)								8	
ID0 (high byte)								9	Factory number (binary-decimal number) (only reading)
ID1									
ID2									
ID3 (low byte)									
Signal								11	Alarm level confirmation (only recording)
Signal									
ID0 (high byte)								12	Serial number (binary-decimal number) (only reading)
ID1									
ID2									
ID3 (low byte)								13	
Reserved									
Address0 (high byte)								21	Address (DWORD) (only recording)
Address1 (low byte)									

Threshold levels are set by recording the required values in registers 0, 1 and 2, 3 for threshold 1 and threshold 2, respectively.

The threshold value is divided into two 16-bit values.

D7	D6	D5	D4	D3	D2	D1	D0	Register address	
Threshold0 (high byte)								0	Threshold 1 (float IEEE 754)
Threshold1									
Threshold2								1	
Threshold3(low byte)									

For recording, it is recommended to use the command to record multiple analog outputs (0x10); It is recommended to use the command for reading analog outputs (0x03) for reading.

#### H.3.4 Communications protocol with the 4-digit address field (v1.2) via Ethernet interface.

To obtain the measured value of DER from the detecting unit, the data display system should transmit the “DER query” frame to the detecting unit. The BS-09 unit will respond with the “Current DER” frame, where current DER, maximum statistic error of its measurement, and self-test results of the detecting unit will be displayed.

To obtain the measured value of temperature from the detecting unit (with an embedded temperature detector), the data display system should transmit the “Temperature query” frame to the detecting unit. The BS-09 unit will respond with the “Current temperature” frame, where current temperature and status of the temperature detector will be provided.

To obtain the serial number of the detecting unit, the data display system should transmit the “Serial # query” frame to the detecting unit. The BS-09 unit will respond with the “Serial #” frame with the displayed serial number.

“DER query” frame format – the data display system to the BS-09 unit:

D7	D6	D5	D4	D3	D2	D1	D0	
0	1	0	1	0	1	0	1	Byte 55h – start-of-frame character
1	0	1	0	1	0	1	0	Byte AAh
0	0	0	0	A3	A2	A1	A0	D7...D4 - “DER query” frame code D3...D0 -BS-09 unit address*

\* - 0Fh address – broadcast address. All detecting units respond to the query with this address.

“Current DER” frame format – the BS-09 unit to the data display system:

D7	D6	D5	D4	D3	D2	D1	D0	
0	1	0	1	0	1	0	1	Byte 55h – start-of-frame character
1	0	1	0	1	0	1	0	Byte AAh
0	0	0	1	A3	A2	A1	A0	D7...D4 - “Current DER” frame code D3...D0 - BS-09 unit address
DER0 (low byte)								DER, fixed point number, Least significant bit (LSB) = 0.01 $\mu$ Sv/h
DER1								
DER2								
DER3 (high byte)								
Byte								Statistic error of measurement
D7	0	0	0	0	D2	D1	D0	D0, D1 - self-test results of the detecting unit D0=1 - failure of the high sensitivity detector D1=1 - failure of the low sensitivity detector Reliable measurement result character D2=0 - result is true D2=1 – result is false* D7=0 – LSB DER = 0,01 $\mu$ Sv/h D7=1 – LSB DER = 0,1 $\mu$ Sv/h
control								arithmetical checksum with a carry

- measurement result is accepted as false if the Statistic error of measurement exceeds maximum permissible error of measurement.

“Temperature query” frame format – the data display system to the BS-09 unit:

D7	D6	D5	D4	D3	D2	D1	D0	
0	1	0	1	0	1	0	1	Byte 55h – start-of-frame character
1	0	1	0	1	0	1	0	Byte AAh
1	0	0	0	A3	A2	A1	A0	D7...D4 - “Temperature query” frame code D3...D0 -BS-09 unit address*

\* - 0Fh address – broadcast address. All detecting units respond to the query with this address.

“Current temperature” frame format – the BS-09 unit to the data display system

D7	D6	D5	D4	D3	D2	D1	D0	
0	1	0	1	0	1	0	1	Byte 55h – start-of-frame character
1	0	1	0	1	0	1	0	Byte AAh
1	0	0	0	A3	A2	A1	A0	D7...D4 - “Current temperature” frame code D3...D0 -BS-09 unit address
$2^3$	$2^2$	$2^1$	$2^0$	$2^{-1}$	$2^{-2}$	$2^{-3}$	$2^{-4}$	Temperature, binary number S=0-above-zero temperature S=1-below-zero temperature
D7	X	X	X	S	$2^6$	$2^5$	$2^4$	D7=0-normal operation of thermal detector D7=1-failure of thermal detector
control								arithmetical checksum with a carry

“Factory # query” frame format – the data display system to the BS-09 unit

D7	D6	D5	D4	D3	D2	D1	D0	
0	1	0	1	0	1	0	1	Byte 55h – start-of-frame character
1	0	1	0	1	0	1	0	Byte AAh
0	1	0	1	A3	A2	A1	A0	D7...D4 - “Factory # query” frame code D3...D0 - BS-09 unit address*

\* - 0Fh address – broadcast address. All detecting units respond to the query with this address.

Factory #” frame format – the BS-09 unit to the data display system

D7	D6	D5	D4	D3	D2	D1	D0	
0	1	0	1	0	1	0	1	Byte 55h – start-of-frame character
1	0	1	0	1	0	1	0	Byte AAh
0	1	0	1	A3	A2	A1	A0	D7...D4 - “Factory #” frame code D3...D0 - BS-09 unit address
Factory No._0 (low byte)								Factory No. of the detecting unit
Factory No._1								
Factory No._2								
Factory No._3 (high byte)								
control								arithmetical checksum with a carry

“Serial # query” frame format – the data display system to the BS-09 unit

D7	D6	D5	D4	D3	D2	D1	D0	
0	1	0	1	0	1	0	1	Byte 55h – start-of-frame character
1	0	1	0	1	0	1	0	Byte AAh
0	1	0	1	A3	A2	A1	A0	D7...D4 - “Serial # query” frame code D3...D0 - BS-09 unit address*

\* - 0Fh address – broadcast address. All detecting units respond to the query with this address.

“Serial #” frame format – the BS-09 unit to the data display system:

D7	D6	D5	D4	D3	D2	D1	D0	
0	1	0	1	0	1	0	1	Byte 55h – start-of-frame character
1	0	1	0	1	0	1	0	Byte AAh
0	1	0	1	A3	A2	A1	A0	D7...D4 - “Serial #” frame code D3...D0 - BS-09 unit address
Serial No._0 (low byte)								Serial No. of the detecting unit
Serial No._1								
Serial No._2								
Serial No._3 (high byte)								
control								arithmetical checksum with a carry



“Threshold query” frame format – the data display system to the BS-09 unit:

D7	D6	D5	D4	D3	D2	D1	D0	
0	1	0	1	0	1	0	1	Byte 55h – start-of-frame character
1	0	1	0	1	0	1	0	Byte AAh
1	1	0	0	A3	A2	A1	A0	D7...D4 - “Threshold query” frame code D3...D0 - BS-09 unit address*

\* - 0Fh address – broadcast address. All detecting units respond to the query with this address.

“Threshold query” frame format – the BS-09 unit to the data display system:

D7	D6	D5	D4	D3	D2	D1	D0	
0	1	0	1	0	1	0	1	Byte 55h – start-of-frame character
1	0	1	0	1	0	1	0	Byte AAh
1	1	0	0	A3	A2	A1	A0	D7...D4 - “Threshold query” frame code D3...D0 - BS-09 unit address*
Threshold0								Threshold_1 (DWORD)
Threshold1								
Threshold2								
Threshold3								
Threshold0								Threshold_2 (DWORD)
Threshold1								
Threshold2								
Threshold3								
control								arithmetical checksum with a carry

“Threshold setting” frame format – the data display system to the BS-09 unit:

D7	D6	D5	D4	D3	D2	D1	D0	
0	1	0	1	0	1	0	1	Byte 55h – start-of-frame character
1	0	1	0	1	0	1	0	Byte AAh
0	1	1	0	A3	A2	A1	A0	D7...D4 - “Threshold setting” frame code D3...D0 - BS-09 unit address*
Threshold0								Threshold_1 (DWORD)
Threshold1								
Threshold2								
Threshold3								
Threshold0								Threshold_2 (DWORD)
Threshold1								
Threshold2								
Threshold3								
control								arithmetical checksum with a carry

“Threshold setting” frame format – the BS-09 unit to the data display system:

D7	D6	D5	D4	D3	D2	D1	D0	
0	1	0	1	0	1	0	1	Byte 55h – start-of-frame character
1	0	1	0	1	0	1	0	Byte AAh
0	1	1	0	A3	A2	A1	A0	D7...D4 - “Threshold setting” frame code D3...D0 - BS-09 unit address*
1/0	0	0	0	0	0	1	1	D7 = 0 – normal operation D7 = 1 - error
control								arithmetical checksum with a carry

“Alarm conformation” frame format – the data display system to the BS-09 unit:

D7	D6	D5	D4	D3	D2	D1	D0	
0	1	0	1	0	1	0	1	Byte 55h – start-of-frame character
1	0	1	0	1	0	1	0	Byte AAh
1	0	0	1	A3	A2	A1	A0	D7...D4 - “Alarm conformation” frame code D3...D0 - BS-09 unit address*

\* - 0Fh address – broadcast address. All detecting units respond to the query with this address.

“Alarm conformation” frame format – the BS-09 unit to the data display system:

D7	D6	D5	D4	D3	D2	D1	D0	
0	1	0	1	0	1	0	1	Byte 55h – start-of-frame character
1	0	1	0	1	0	1	0	Byte AAh
1	0	0	1	A3	A2	A1	A0	D7...D4 - “Alarm conformation” frame code D3...D0 - BS-09 unit address*
1/0	0	0	0	0	0	1	1	D7 = 0 - normal operation D7 = 1 - error
control								arithmetical checksum with a carry

Communications protocol with the 8-digit address field (v1.3) via Ethernet interface.

To obtain the measured value of DER from the detecting unit, the data display system should transmit the “DER1 query” frame to the detecting unit. The detecting unit will respond with the “Current DER1” frame, where current DER, maximum Statistic error of its measurement, and self-test results of the detecting unit will be displayed.

To obtain the measured value of temperature from the detecting unit (with an embedded temperature detector), the data display system should transmit the “Temperature1 query” frame to the detecting unit. The detecting unit will respond with the “Current temperature1” frame, where current temperature and status of the temperature detector will be provided.

To obtain the serial number of the detecting unit and the response delay factor to broadcast query, the data display system should send the “Serial #\_1 query” frame to the detecting unit. The detecting unit will respond with the “Serial #\_1” frame with the displayed serial number and the response delay factor to the broadcast query.

“DER1 query” frame format – the data display system to the detecting unit:

D7	D6	D5	D4	D3	D2	D1	D0	
0	1	0	1	0	1	0	1	Byte 55h – start-of-frame character
1	0	1	0	1	0	1	0	Byte AAh
0	1	1	1	0	0	0	0	D7...D4–protocol v1.3 character
address								D7...D0– BS-09 unit address*
0	0	0	0	0	0	0	0	D7...D0–“DER1 query” frame code
control								arithmetical checksum with a carry

\* - 0Fh address – broadcast address. All detecting units respond to the query with this address.

“Current DER1” frame format – the detecting unit to the data display system:

D7	D6	D5	D4	D3	D2	D1	D0	
0	1	0	1	0	1	0	1	Byte 55h – start-of-frame character
1	0	1	0	1	0	1	0	Byte AAh
0	1	1	1	0	0	0	0	D7...D4–protocol v1.3 character
address								D7...D0– BS-09 unit address
0	0	0	0	0	0	0	1	D7...D0–“Current DER1” frame code
DER0 (low byte)								DER, fixed point number, Least significant bit = 0.01 $\mu$ Sv/h
DER1								
DER2								
DER3 (high byte)								
Byte								Statistic error of measurement
								D0,D1 - self-test results of the detecting unit D0=1 - failure of the high sensitivity detector D1=1 - failure of the low sensitivity detector Reliable measurement result character D2=0 - result is true D2=1 – result is false * D7=0 – LSB DER = 0,01 $\mu$ Sv/h D7=1 – LSB DER = 0,1 $\mu$ Sv/h
D7	0	0	0	0	D2	D1	D0	
control								arithmetical checksum with a carry

\* - measurement result is accepted as false if the Statistic error of measurement exceeds maximum permissible error of measurement.

“Temperature1 query” frame format – the data display system to the detecting unit:

D7	D6	D5	D4	D3	D2	D1	D0	
0	1	0	1	0	1	0	1	Byte 55h – start-of-frame character
1	0	1	0	1	0	1	0	Byte AAh
0	1	1	1	0	0	0	0	D7...D4–protocol v1.3 character
address								D7...D0–BS-09 unit address*
0	0	0	0	1	0	0	0	D7...D0–“Temperature1 query” frame code
control								arithmetical checksum with a carry

\* - 0Fh address – broadcast address. All detecting units respond to the query with this address.

“Current temperature1” frame format – the detecting unit to the data display system:

D7	D6	D5	D4	D3	D2	D1	D0	
0	1	0	1	0	1	0	1	Byte 55h – start-of-frame character
1	0	1	0	1	0	1	0	Byte AAh
0	1	1	1	0	0	0	0	D7...D4–protocol v1.3 character
address								D7...D0–BS-09 unit address
0	0	0	0	1	0	0	0	D7...D0–“Current temperature1” frame code
$2^3$	$2^2$	$2^1$	$2^0$	$2^{-1}$	$2^{-2}$	$2^{-3}$	$2^{-4}$	Temperature, binary number S=0-above-zero temperature S=1-below-zero temperature
D7	X	X	X	S	$2^6$	$2^5$	$2^4$	D7=0-normal operation of thermal detector D7=1-failure of thermal detector
control								arithmetical checksum with a carry

“Factory #1 query” frame format – the data display system to the detecting unit:

D7	D6	D5	D4	D3	D2	D1	D0	
0	1	0	1	0	1	0	1	Byte 55h – start-of-frame character
1	0	1	0	1	0	1	0	Byte AAh
0	1	1	1	0	0	0	0	D7...D4–protocol v1.3 character
address								D7...D0–BS-09 unit address*
0	0	0	0	0	1	0	1	D7...D0–“Factory #1 query” frame code
control								arithmetical checksum with a carry

\* - 0Fh address – broadcast address. All detecting units respond to the query with this address.

“Factory #\_1” frame format – the detecting unit to the data display system

D7	D6	D5	D4	D3	D2	D1	D0	
0	1	0	1	0	1	0	1	Byte 55h – start-of-frame character
1	0	1	0	1	0	1	0	Byte AAh
0	1	1	1	0	0	0	0	D7...D4–protocol v1.3 character
address								D7...D0–BS-09 unit address
0	0	0	0	0	1	0	1	D7...D0–“Factory #_1” frame code
Factory No._0 (low byte)								Factory No. of the detecting unit
Factory No._1								
Factory No._2								
Factory No._3 (high byte)								
current constant								D7...D0 – current response delay factor to broadcast query
control								arithmetical checksum with a carry

“Serial #\_1 query” frame format – the data display system to the detecting unit:

D7	D6	D5	D4	D3	D2	D1	D0	
0	1	0	1	0	1	0	1	Byte 55h – start-of-frame character
1	0	1	0	1	0	1	0	Byte AAh
0	1	1	1	0	0	0	0	D7...D4–protocol v1.3 character
address								D7...D0–BS-09 unit address*
0	0	0	0	0	1	0	1	D7...D0–“Serial #_1 query” frame code
control								arithmetical checksum with a carry

\* - 0Fh address – broadcast address. All detecting units respond to the query with this address.

“Serial #\_1” frame format – the detecting unit to the data display system

D7	D6	D5	D4	D3	D2	D1	D0	
0	1	0	1	0	1	0	1	Byte 55h – start-of-frame character
1	0	1	0	1	0	1	0	Byte AAh
0	1	1	1	0	0	0	0	D7...D4–protocol v1.3 character
address								D7...D0–BS-09 unit address
0	0	0	0	0	1	0	1	D7...D0–“Serial #_1” frame code
Serial No._0 (low byte)								Serial No. of the detecting unit
Serial No._1								
Serial No._2								
Serial No._3 (high byte)								
current constant								D7...D0 – current response delay factor to broadcast query
control								arithmetical checksum with a carry



“Threshold query1” frame format – the data display system to the BS-09 unit:

D7	D6	D5	D4	D3	D2	D1	D0	
0	1	0	1	0	1	0	1	Byte 55h – start-of-frame character
1	0	1	0	1	0	1	0	Byte AAh
0	1	1	1	0	0	0	0	D7...D4–protocol v1.3 character
address								D7...D0–BS-09 unit address
0	0	0	0	1	1	0	0	D7...D0–“Threshold query1” frame code
control								arithmetical checksum with a carry

\* - 0Fh address – broadcast address. All detecting units respond to the query with this address.

“Threshold query1” frame format – the BS-09 unit to the data display system:

D7	D6	D5	D4	D3	D2	D1	D0	
0	1	0	1	0	1	0	1	Byte 55h – start-of-frame character
1	0	1	0	1	0	1	0	Byte AAh
0	1	1	1	0	0	0	0	D7...D4–protocol v1.3 character
address								D7...D0–BS-09 unit address
0	0	0	0	1	1	0	0	D7...D0–“ Threshold query1” frame code
Threshold0								Threshold_1 (DWORD)
Threshold1								
Threshold2								
Threshold3								
Threshold0								Threshold_2 (DWORD)
Threshold1								
Threshold2								
Threshold3								
control								arithmetical checksum with a carry

“Threshold setting1” frame format – the data display system to the BS-09 unit:

D7	D6	D5	D4	D3	D2	D1	D0	
0	1	0	1	0	1	0	1	Byte 55h – start-of-frame character
1	0	1	0	1	0	1	0	Byte AAh
0	1	1	0	0	0	0	0	D7...D4–protocol v1.3 character
address								D7...D0–BS-09 unit address
0	0	0	0	0	1	1	0	D7...D0–“Threshold setting1” frame code
Threshold0								Threshold_1 (DWORD)
Threshold1								
Threshold2								
Threshold3								
Threshold0								Threshold_2 (DWORD)
Threshold1								
Threshold2								
Threshold3								
control								arithmetical checksum with a carry

“Threshold setting1” frame format – the BS-09 unit to the data display system:

D7	D6	D5	D4	D3	D2	D1	D0	
0	1	0	1	0	1	0	1	Byte 55h – start-of-frame character
1	0	1	0	1	0	1	0	Byte AAh
0	1	1	0	0	0	0	0	D7...D4–protocol v1.3 character
address								D7...D0–BS-09 unit address
0	0	0	0	0	1	1	0	D7...D0–“ Threshold setting1” frame code
1/0	0	0	0	0	0	1	1	D7 = 0 – normal operation D7 = 1 - error
control								arithmetical checksum with a carry

“Alarm conformation1” frame format – the data display system to the BS-09 unit:

D7	D6	D5	D4	D3	D2	D1	D0	
0	1	0	1	0	1	0	1	Byte 55h – start-of-frame character
1	0	1	0	1	0	1	0	Byte AAh
0	1	1	1	0	0	0	0	D7...D4–protocol v1.3 character
address								D7...D0–BS-09 unit address
0	0	0	0	1	0	0	1	D7...D0–“Alarm conformation1” frame code
control								arithmetical checksum with a carry

\* - 0Fh address – broadcast address. All detecting units respond to the query with this address.

“Alarm conformation1” frame format – the BS-09 unit to the data display system:

D7	D6	D5	D4	D3	D2	D1	D0	
0	1	0	1	0	1	0	1	Byte 55h – start-of-frame character
1	0	1	0	1	0	1	0	Byte AAh
0	1	1	1	0	0	0	0	D7...D4–protocol v1.3 character
address								D7...D0–BS-09 unit address
0	0	0	0	1	0	0	1	D7...D0–“Alarm conformation1” frame code”
1/0	0	0	0	0	0	1	1	D7 = 0 - normal operation D7 = 1 - error
control								arithmetical checksum with a carry

H.3.5 The checksum in the case of information exchange protocol v1.2, and in the case of information exchange protocol v1.3, is calculated in accordance with Figure H.1.

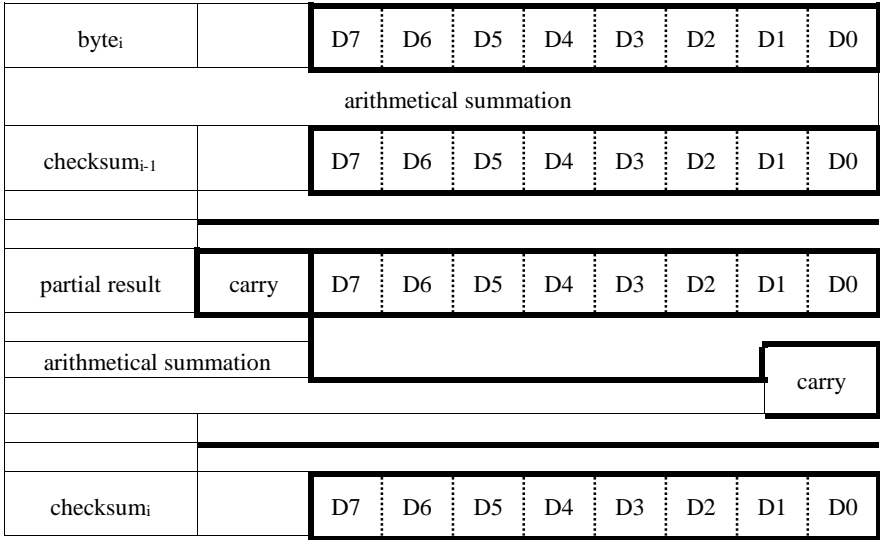

Figure H.1 - Checksum calculation algorithm

### H.3.6 “ModBusTCP” protocol via Ethernet

To obtain the measured value of DER from the detecting unit, the data display system must read data from two registers with numbers four and five (4 and 5). The resulting 16-bit numbers must be combined into a 32-bit one and converted to an IEEE 754 format float.

The BS-09 unit will respond under the “ModBusTCP” protocol with data on the current DER.

D7	D6	D5	D4	D3	D2	D1	D0	Register address	
DER0 (low byte)								4	Current DER (float IEEE 754)
DER1									
DER2								5	
DER3 (high byte)									

To obtain the measured value of temperature from the BS-09 unit, the data display system must read data from two registers with numbers seven and eight (7 and 8). The resulting 16-bit numbers must be combined into a 32-bit one and converted to an IEEE 754 format float.

D7	D6	D5	D4	D3	D2	D1	D0	Register address	
Temp0 (low byte)								7	Temperature (float IEEE 754)
Temp1									
Temp2								8	
Temp 3 (high byte)									

**Important!!!** You do not need to use an address to apply the “ModBusTCP” protocol, as it will refer by specific IP address.

The BS-09 unit will respond with confirmation under the “ModBusTCP” protocol.

To confirm the alarm of exceeding one of the two threshold levels, you need to record 1 to the register with address 11. It is recommended for recording to use the command to write analog output for recording (0x06);

Memory structure for “ModBusTCP” protocol.

D7	D6	D5	D4	D3	D2	D1	D0	Register address	
Threshold0 (high byte)								0	Threshold 1 (float IEEE 754)
Threshold1									
Threshold2									
Threshold3(low byte)								1	
Threshold0 (high byte)								2	Threshold 2 (float IEEE 754)
Threshold1									
Threshold2									
Threshold3(low byte)								3	
DER0 (high byte)								4	DER (float IEEE 754)
DER1									
DER2									
DER3 (low byte)								5	(only reading)
Self-test results								6	Two 16-bit integers
Statistical error									
Temp0 (high byte)								7	Temperature (float IEEE 754)
Temp1									
Temp2									
Temp3 (low byte)								8	(only reading)
ID0 (high byte)								9	Factory number (binary-decimal number)
ID1									
ID2									
ID3 (low byte)								10	(only reading)
Signal								11	Alarm level confirmation (only recording)
Signal									
ID0 (high byte)								12	Serial number (binary-decimal number)
ID1									
ID2									
ID3 (low byte)								13	(only reading)
Reserved									
Address0 (high byte)								21	Address (DWORD) (only recording)
Address1 (low byte)									

Threshold levels are set by recording the required values in registers 0, 1 and 2, 3 for threshold 1 and threshold 2, respectively. The threshold value is divided into two 16-bit values.

D7	D6	D5	D4	D3	D2	D1	D0	Register address	
Threshold0 (high byte)								0	Threshold 1 (float IEEE 754)
Threshold1									
Threshold2								1	
Threshold3(low byte)									

For recording, it is recommended to use the command to record multiple analog outputs (0x10); It is recommended to use the command for reading analog outputs (0x03) for reading;

### H.3.7 Commands of the Ethernet interface under HTTP protocol

To obtain the measured value of DER, the current temperature and self-test results from the detecting unit, the data display system must send a query under the http protocol:

http://ip\_addr:port/GDAT=

The BS-09 unit will respond under the http protocol with the following line:

ID (7 hex digits)	Temperature	DER	Stat. error.	SelfTest
XXXXXXXX,	float,	float,	uint8_t,	uint8_t;

where ID - 7 digits.

DER, Temperature - float number with 2 significant digits.

Static error is a number from 255 to 0.

SelfTest – self-test results of the detecting unit.

SelfTest – uint8\_t - 0x- D6 - - - D2 D1 D0

D6 = 1 – No connection to the detecting unit;

D2 = 0 – Reliable data, D2 = 1 – Unreliable data;

D1 = 1 – Failure of the LS detector;

D0 = 1 - Failure of the HS detector;

For example: 1401179,23.56,0.13,17,0;

Method	Command	Parameters	Response	Note
GET	GDAT=		1401179,23.563, 0.13,17,0;	DER, temperature, static error and self-test results
GET			html code of the page	Web interface of the device for settings
GET	index.html			
GET	GLOG=		13, 50, 33, 5, 31, 21, 3e, 2e, 14, 7b <sup>4</sup>	Unloading logs (bytes array)
GET	SSIG=		OK	Alarm confirmation
POST	GSET=	PIN (xx0xx0xx0xx 0xx)	Array of settings	Unload settings x is any number
GET	SMAD=	int (16 bit)	OK/WRONG	Setting the address for commands under the RS-485 interface
POST	SSET=	Array of settings	OK/	Make settings
GET	SRTC=	5M;14D;19Y; 15H;35M;43S;	OK/WRONG	Set time and date

---

<sup>4</sup> Means that the record was done on May 31, 2021 at 13 hours 50 minutes 33 seconds with the DER value equal to 0.17 (0x3e2e147b)



PIN details. It consists of 14 digits, where only 4 digits are the PIN code itself. Thus the PIN looks as follows:

xx      D0      xx      D1      xx      D2      xx      D3      xx

Thus, xx shows any double digits, and the PIN itself is formed as follows: for example, PIN of the BS-09 unit is 1234.

Then D0 = 1, D1 = 2, D2 = 3, D3 = 4. The BS-09 unit will respond to the PIN command with the expected result only when the PIN is correct.

If there is an internal error or incorrect PIN, the BS-09 unit will respond under the http protocol with the content “WRONG”.

Detailed description of SSET = parameters of this command are the array of settings described below

Parameter	Example	Note
DHCP=	1/0;	Switching between DHCP and manual address entry
MAC=	FF:FF:FF:FF:FF:FF;	Setting the MAC address
PORT=	80;	Port selection
LTHR=	2.1;	Setting thresholds
HTHR=	50.0;	
VOL=	1/0;	Sound
IPAD=	FF.FF.FF.FF;	IP-address
NETM=	FF.FF.FF.FF;	Net mask
GATE=	FF.FF.FF.FF;	Gateway address
BAUD=	19200;	Baudrate
REL1=	1/0;	Initial state of the relay
REL2=	5000;	Time to turn on
REL3=	10000;	Time to turn off
LTIM=	5;	Login interval

**IMPORTANT!!!** To activate the parameters DHCP=, MAC=, PORT=, IPAD=, NETM=, GATE=, BAUD=, the BS-09 unit will reboot.

## ANNEX J

J.1 To connect the BDBG-09 detecting unit to the BS-09 unit, it is equipped with the “**RS-485 OUT**” interface connector CA6GS 932326-100 HIRSCHMANN. The following signals are output to this connector:

Signal	pin
circuit A (RS-485)	1
circuit B (RS-485)	2
reserve	3
supply voltage	4
total	5
screen	6
screen	7

J.2 To connect the external system for information collection and display to the BS-09 unit via the RS-485 interface and/or supply power to the BS-09 unit, it is equipped with the “**RS-485 IN**” interface connector CA6GS 932326-100 HIRSCHMANN. The following signals are output to this connector:

Signal	pin
circuit A (RS-485)	1
circuit B (RS-485)	2
reserve	3
supply voltage	4
total	5
screen	6
screen	7

J.3 To connect the external system for information collection and display to the BS-09 unit via the Ethernet interface and/or supply power to the BS-09 unit using PoE technology, it is equipped with an “**ETHERNET**” interface connector 17-110814 CONNEC. The following signals are output to this connector:

Signal	T-568A	T-568B	pin
Tx+	white and green	white and orange	1
Tx-	green	orange	2
Rx+	white and orange	white and green	3
DC+ PoE	blue	blue	4
DC+ PoE	white and blue	white and blue	5
Rx-	orange	green	6
DC- PoE	white and brown	white and brown	7
DC- PoE	brown	brown	8
screen	housing	housing	9

J.4 To connect power supply to the BS-09 unit and/or to control the external load, it is equipped with the “**DC IN**” 0270-04 LUMBERG connector. The following signals are output to this connector:

Signal	pin
supply voltage	1
total	2
NC	3
COM	4

## ANNEX K

### COMMENDATIONS FOR CABLE CHOICE FOR CONNECTING THE BDBG-09 DETECTING UNIT TO THE BS-09 UNIT AND FOR CONNECTING THE BS-09 UNIT TO THE INFORMATION COLLECTION AND DISPLAY SYSTEM VIA RS-485 INTERFACE

To ensure stable data communication between the BDBG-09 detecting unit and the BS-09 unit, stable data communication between the BS-09 unit and the information collection and display system via the RS-485 interface, you should use a cable with the following parameters:

- number of twisted pairs: not less than 2 (unused pairs to be connected to the negative power supply from the side of power supply to the cable);
- cross section of the conductor: from 0.22 to 0.75 mm<sup>2</sup>;
- wave impedance: from 100 to 120 Ohms;
- the presence of a common screen: yes;
- screen material: foil + copper basketweave (in case of using an individual shielding metal sheath, the use of a cable without an additional screen made of copper basketweave is allowed);
- outer diameter: from 6 to 12 mm (to ensure the tightness of the Hirschmann CA6LD connector);
- resistance to mechanical and climatic factors: depending on operating conditions;
- active resistance per unit length: depending on the cable length according to the formula (K.1) (determined based on the need to ensure the supply voltage of the detecting unit within acceptable limits at maximum current consumption):

$$R_{ul} \leq \frac{U_{in} - U_{min}}{2 \cdot l \cdot I_{max}}, \quad (K.1)$$

where

$R_{ul}$  - active resistance per unit length, Ohm/m;

$U_{in}$  - voltage at the cable input (not more than 13 V), V;

$U_{min} = 7$  V - the minimum allowable supply voltage of the BDBG-09 detecting unit in accordance with the OM;

$I_{max} = 0.03$  A - the maximum current consumption of the BDBG-09 detecting unit in accordance with the OM;

$l$  - cable length, m.

- capacitance per unit length: depending on the cable length according to the formula (K.2) (determined based on the need to ensure the duration of the front when transmitting one bit of information less than  $\frac{1}{4}$  the total transmission time of this bit):

$$C_{ul} \leq \frac{1}{S \cdot 4 \cdot R_{ul} \cdot l^2}, \quad (\text{K.2})$$

where

$C_{ul}$  - capacitance per unit length, F/m;

$R_{ul}$  - active resistance per unit length, Ohm/m;

$S$  - data exchange rate, 19200 bps;

$l$  - cable length, m.

## **ANNEX L**

### **COMMENDATIONS FOR CABLE CHOICE FOR CONNECTING THE BS-09 UNIT TO THE INFORMATION COLLECTION AND DISPLAY SYSTEM VIA ETHERNET INTERFACE**

To ensure stable data communication between the BS-09 unit and the information collection and display system via the Ethernet interface, it is necessary to use a shielded cable FTP-cat.5E with a shielded connector RJ45 cat.5e.

## ANNEX M

Power supply circuit of the BS-09 unit and connection of the BDBG-09 unit

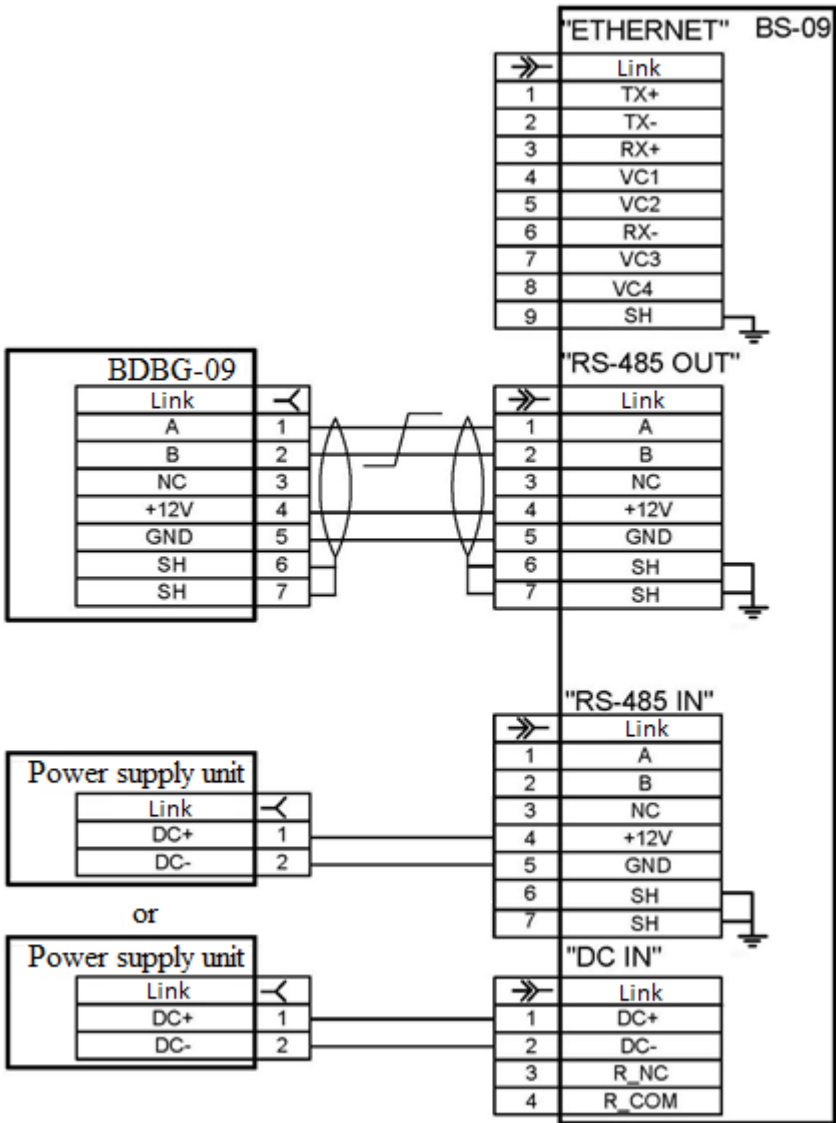

## ANNEX N

Power supply and communication circuit with the external system of information collection and display through the “ETHERNET” connector of the BS-09 unit and connecting the BDBG-09 unit

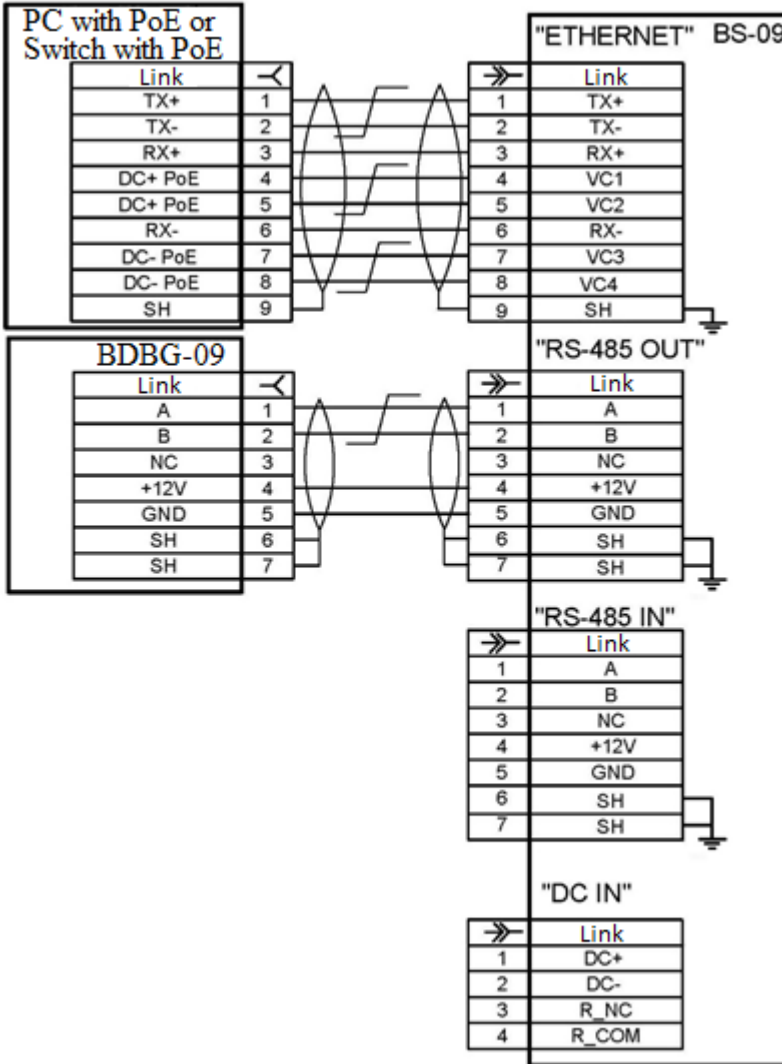



## ANNEX P

Communication circuit with the external system of information collection and display through the “RS-485 IN” connector of the BS-09 unit and connecting the BDBG-09 unit

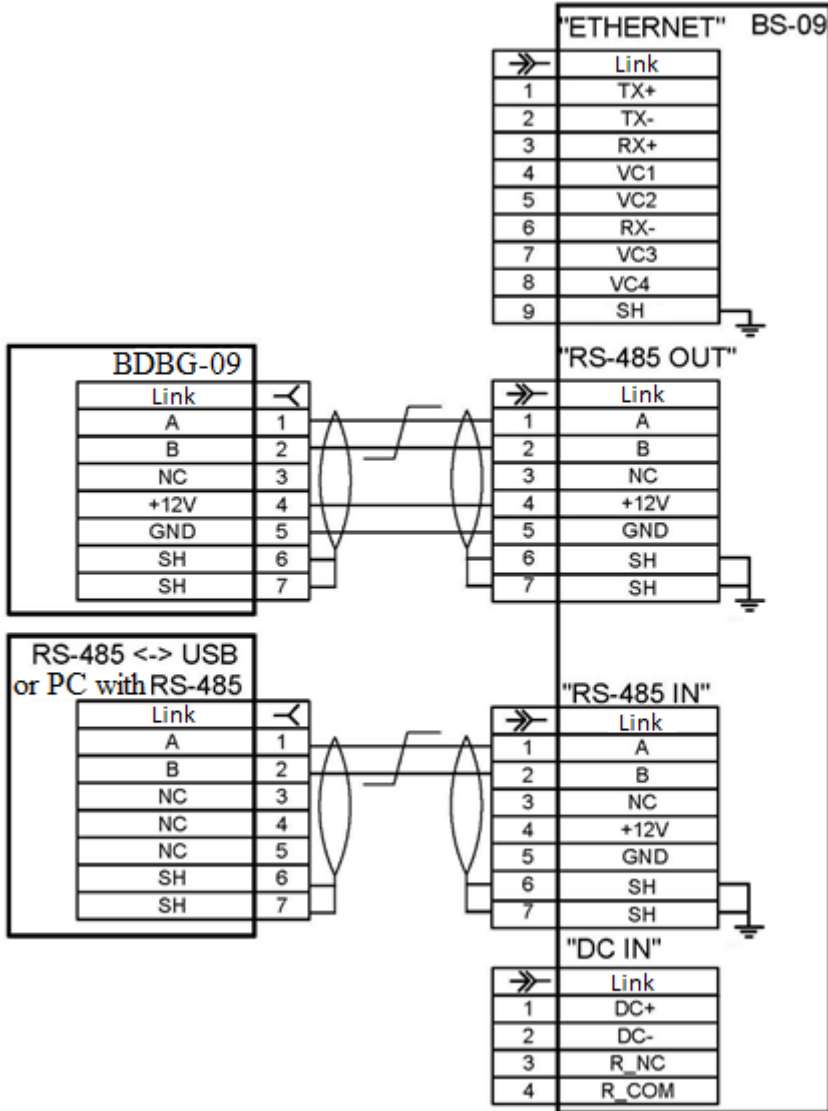

## **SPECIAL NOTES**



